

HCT/EC

Tubular axial fans, with EC Technology IE5 motor



← EC TECHNOLOGY MOTOR with integrated electronics



← EC CONTROL Supplied as an optional accessory

Tubular axial fans with EC Technology IE5 motor with integrated electronics, specially designed for high energy efficiency.

Fan:

- Airflow direction from motor to impeller.
- Fibreglass reinforced polyamide-6 impeller. AL version made of cast aluminium.
- Long tubular casing in sheet steel with external terminal box.

Motor:

- High efficiency EC Technology motors with integrated electronics, regulated by 0-10 V or 4-20 mA.
- IE5 efficiency motors, class F and IP55 protection.
- Single-phase 230 V 50/60 Hz and three-phase 400 V 50/60 Hz.
- Working temperature: -25 °C +60 °C.

EC CONTROL: Supplied as an optional accessory. Control panel for ventilation

systems with EC Technology motors with the electronics integrated in the motor itself. With the following characteristics:

- CPC: Constant pressure control.
- CFC: Constant flow control.
- DAY/NIGHT: Double pressure setpoint adjustment according to time of day.
- External sensor: compatible with temperature, humidity, air quality or CO sensor.
- Equipment preconfigured in constant pressure mode with 100 Pa set point.

Finish:

- Anti-corrosive finish in polyester resin, polymerised at 190 °C, after degreasing with phosphate-free nanotechnology treatment.

On request:

- Airflow direction from impeller to motor.
- 100% reversible impellers.

Order code

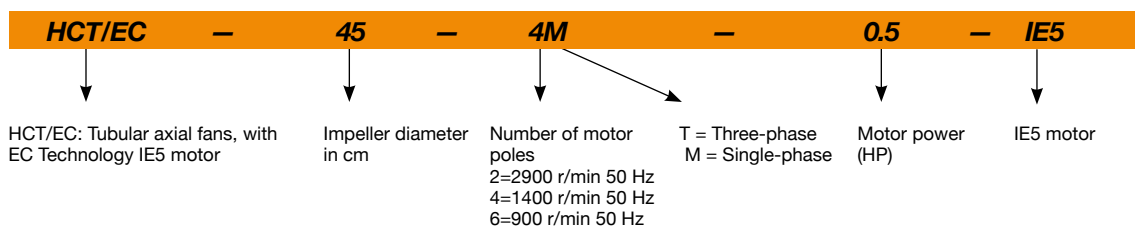

Technical characteristics

Model	Speed (r/min)	Maximum admissible current (A)		Max. electric power (kW)	Maximum flow rate (m³/h)	Sound pressure level dB (A)	Approx. weight (Kg)	According ErP*
		230V	400V					
HCT/EC-45-2T-3 IE5	2910		6.1	2.20	12750	88	39	2020
HCT/EC-45-4M-0.5 IE5	1400	3.4		0.37	7100	68	24	2020
HCT/EC-50-4M-0.75 IE5	1350	4.8		0.55	10400	70	28	2020
HCT/EC-56-4M-1.5 IE5	1455	8.9		1.10	14000	74	40	2020
HCT/EC-63-4M-1.5 IE5	1455	8.9		1.10	17000	74	49	2020
HCT/EC-63-4T-3 IE5	1435		5.9	2.20	22100	76	58	2020
HCT/EC-71-4T-3 IE5	1435		5.9	2.20	23950	81	65	2020
HCT/EC-71-6M-1 IE5	940	5.9		0.75	17250	68	58	2020
HCT/EC-80-4T-3 IE5	1435		5.9	2.20	28000	82	73	2020
HCT/EC-80-4T-5.5 IE5	1450		10.6	4.00	37200	84	81	2020
HCT/EC-90-4T-5.5 IE5	1450		10.6	4.00	41850	89	97	2020
HCT/EC-90-6T-3 IE5	950		7.5	2.20	35000	78	96	2020
HCT/EC-100-6T-3 IE5	950		7.5	2.20	40500	82	107	2020

* In accordance with the ErP 2020 draft



Erp. (Energy Related Products)

Information on Directive 2009/125/EC can be downloaded from the SODECA website or the QuickFan selector programme.

Acoustic characteristics

The indicated values are determined by measuring the pressure and sound power levels in dB(A) obtained in a free field at a distance equivalent to twice the size of the fan plus the impeller diameter, with a minimum of 1.5 m.

Sound power spectrum Lw(A) in dB(A) per Hz frequency band

	63	125	250	500	1000	2000	4000	8000
HCT/EC-45-2T-3	53	70	82	90	95	95	91	84
HCT/EC-45-4M-0.5	33	50	62	70	75	75	71	64
HCT/EC-50-4M-0.75	37	54	67	74	79	80	75	68
HCT/EC-56-4M-1.5	49	69	77	82	84	81	74	63
HCT/EC-63-4M-1.5	51	71	79	84	86	83	76	65
HCT/EC-63-4T-3	53	73	81	86	88	85	78	67
HCT/EC-71-4T-3	58	78	86	91	93	90	83	72
HCT/EC-71-6M-1	45	65	73	78	80	77	70	59
HCT/EC-80-4T-3	59	79	87	92	94	91	84	73
HCT/EC-80-4T-5.5	61	81	89	94	96	93	86	75
HCT/EC-90-4T-5.5	67	88	95	100	103	99	92	81
HCT/EC-90-6T-3	56	77	84	89	92	88	81	70
HCT/EC-100-6T-3	62	82	90	95	97	94	87	76

Dimensions mm

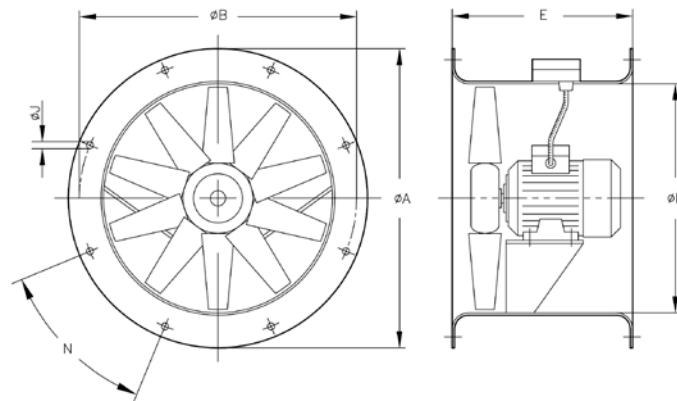

	ØA	ØB	ØD	E	ØJ	N
HCT/EC-45	540	500	460	360	12	8x45°
HCT/EC-50	600	560	514	360	12	12x30°
HCT/EC-56	660	620	560	400	12	12x30°
HCT/EC-63	730	690	640	430	12	12x30°
HCT/EC-71	810	770	710	500	12	16x22°30'
HCT/EC-80	900	860	800	500	12	16x22°30'
HCT/EC-90	1015	970	900	500	15	16x22°30'
HCT/EC-100	1115	1070	1000	600	15	16x22°30'

Characteristic curves

Q= Flow rate in m³/h, m³/s and cfm

Pe= Static pressure in mm H₂O, Pa and inwg

HCT/EC-45-2T-3

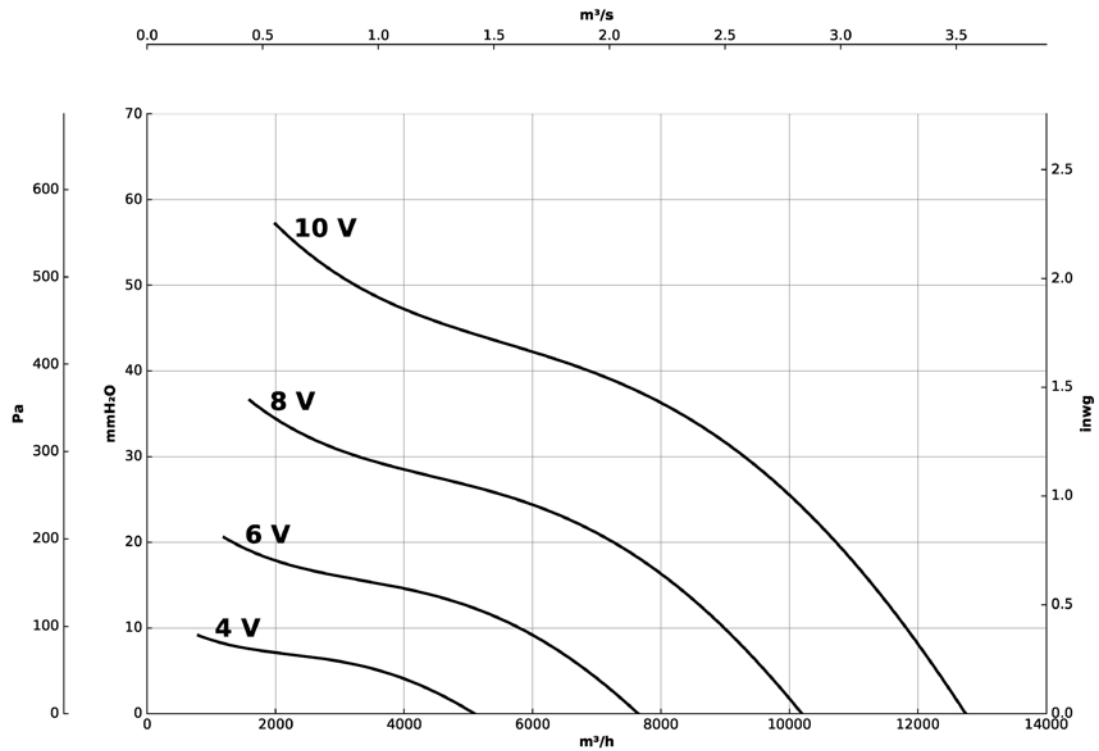

HCT/EC-45-4M-0.5

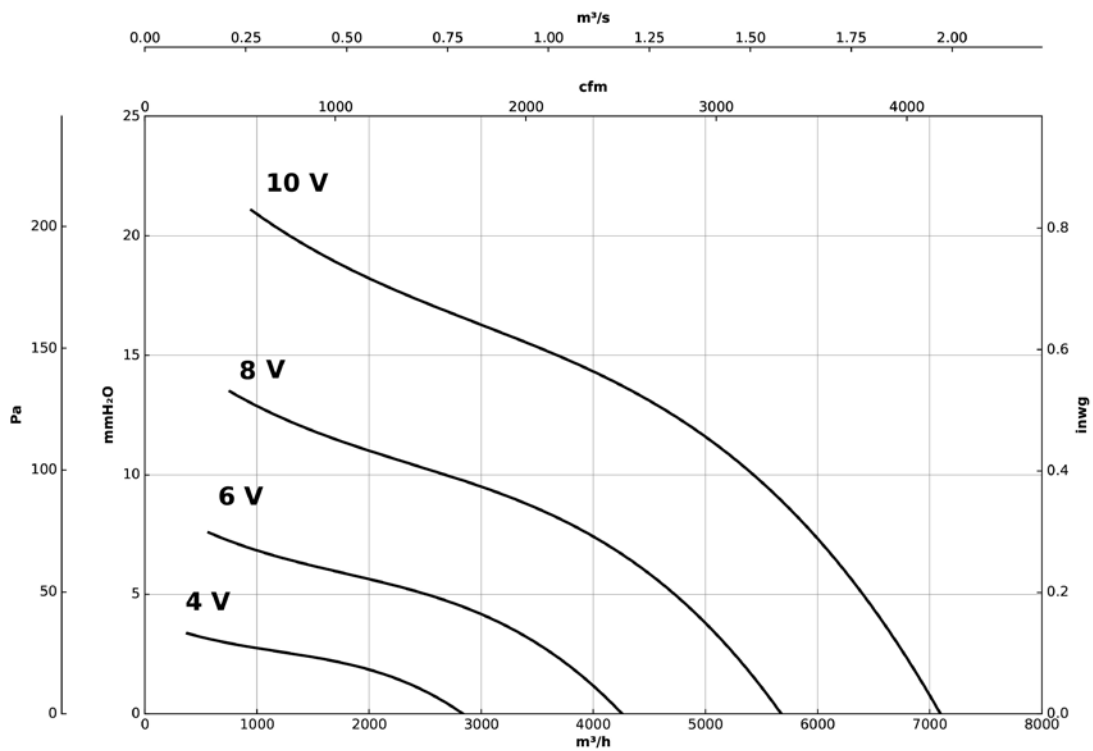

Characteristic curves

Q= Flow rate in m³/h, m³/s and cfm

Pe= Static pressure in mm H₂O, Pa and inwg

HCT/EC-50-4M-0.75

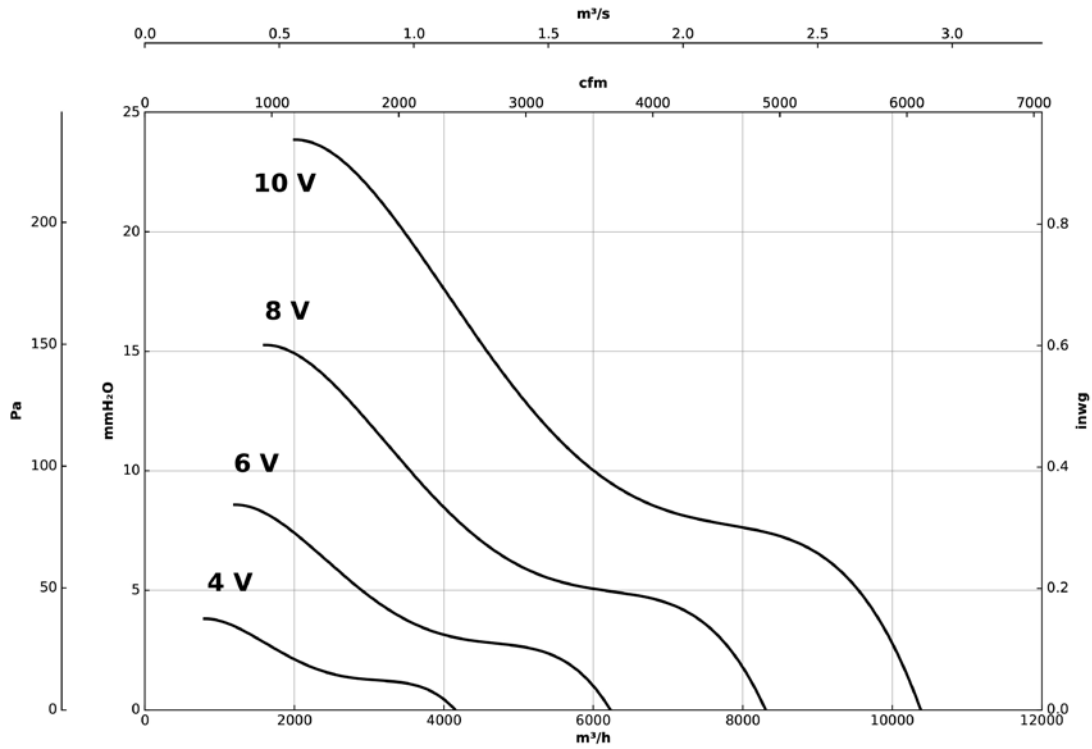

HCT/EC-56-4M-1.5

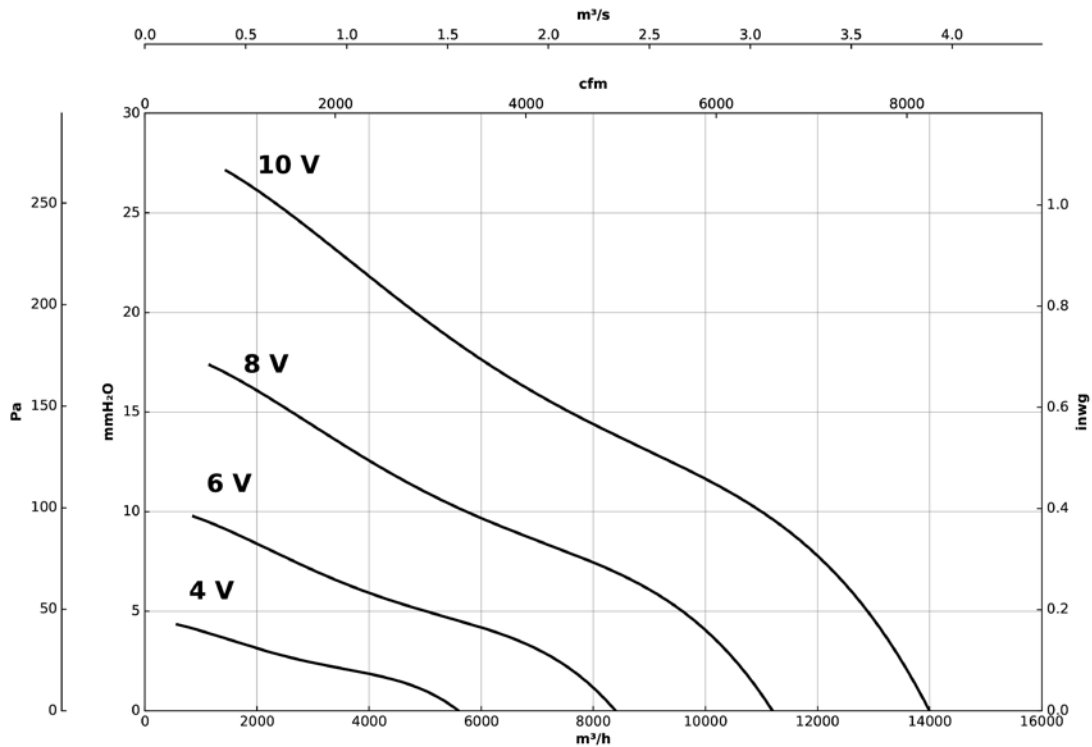

Characteristic curves

Q= Flow rate in m³/h, m³/s and cfm

Pe= Static pressure in mm H₂O, Pa and inwg

HCT/EC-63-4M-1.5

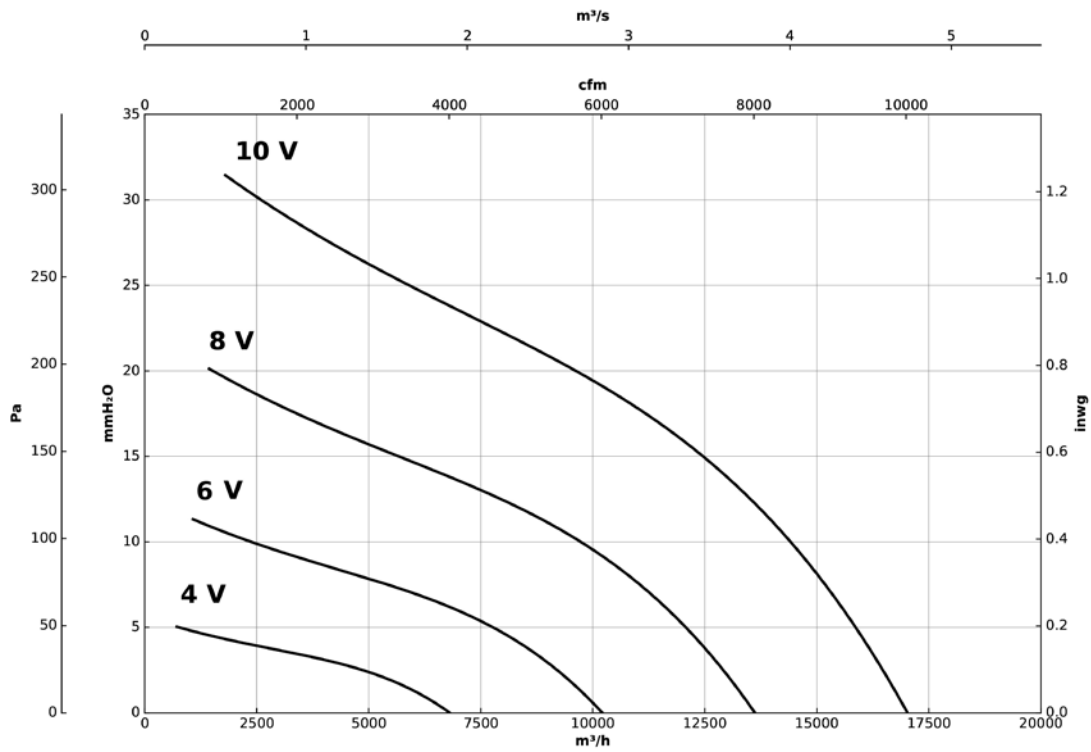

HCT/EC-63-4T-3

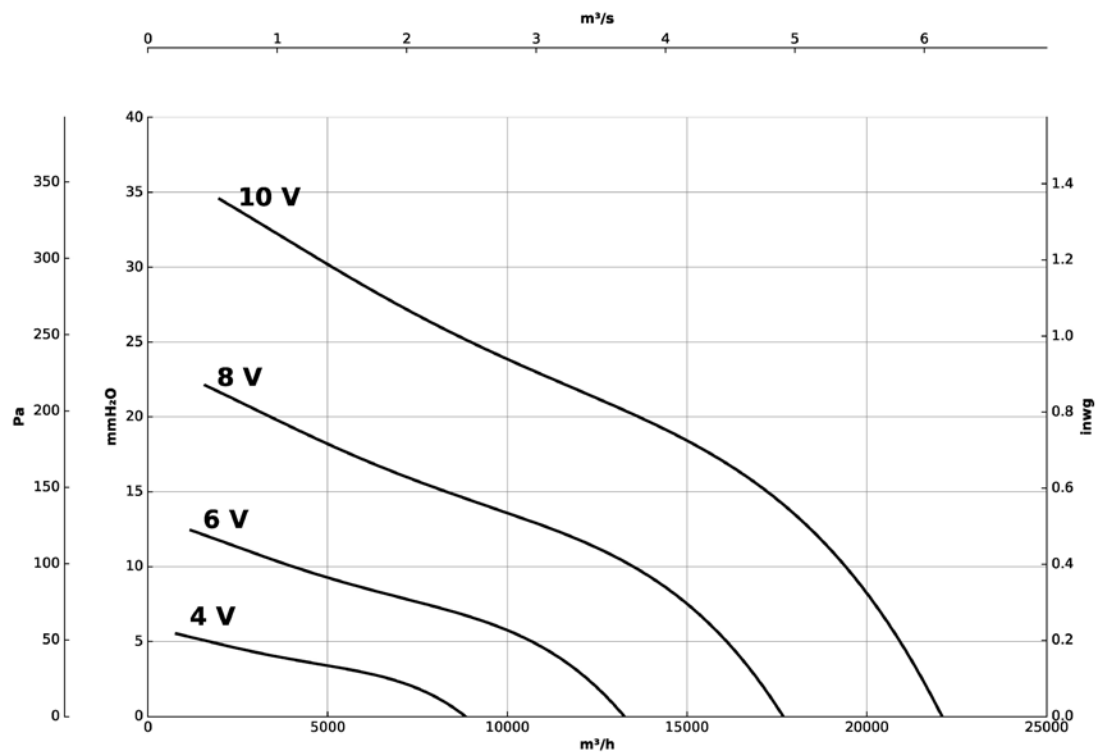

Characteristic curves

Q= Flow rate in m³/h, m³/s and cfm

Pe= Static pressure in mm H₂O, Pa and inwg

HCT/EC-71-4T-3

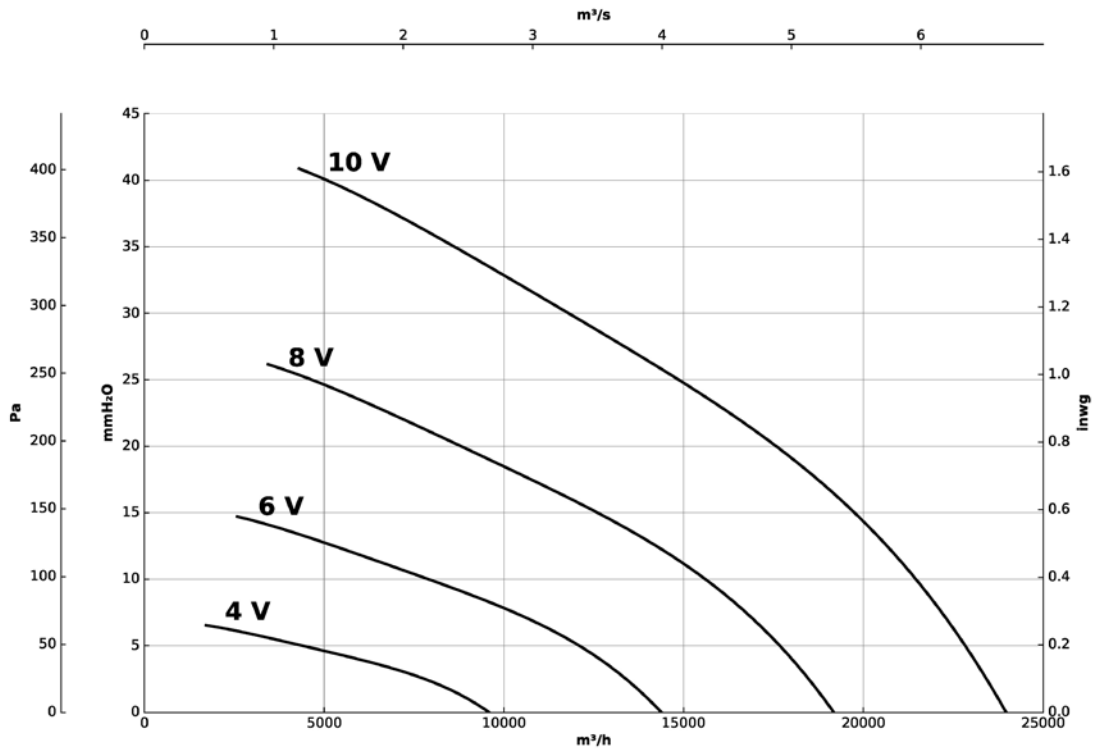

HCT/EC-71-6M-1

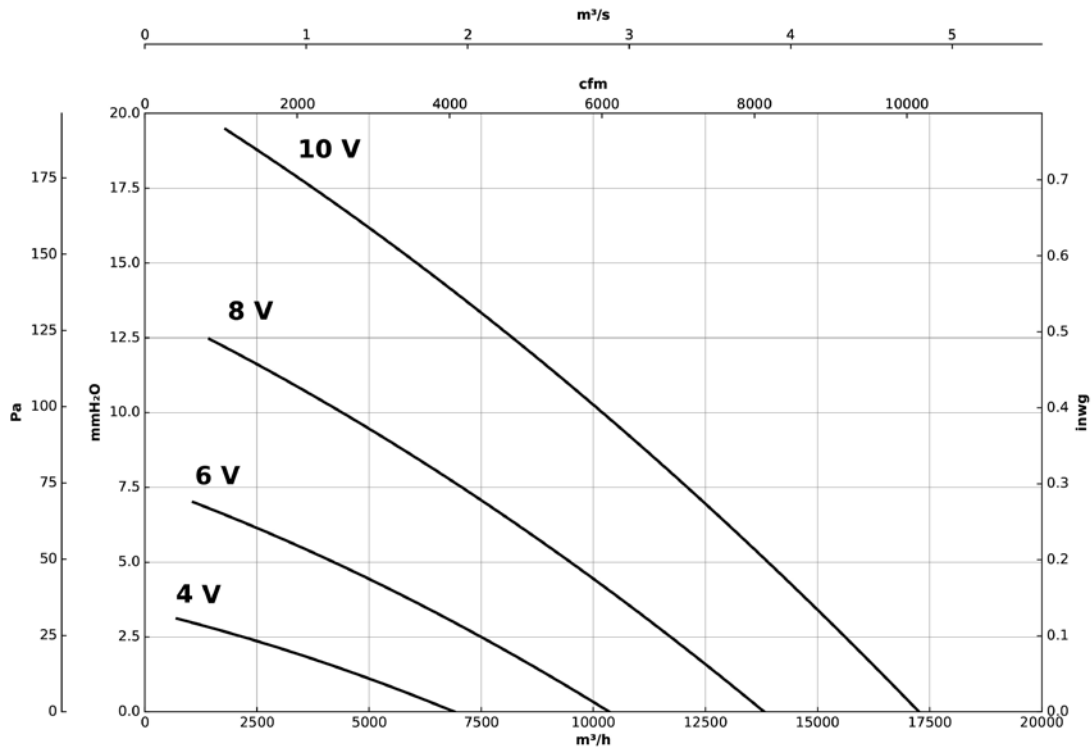

Characteristic curves

Q= Flow rate in m³/h, m³/s and cfm

Pe= Static pressure in mm H₂O, Pa and inwg

HCT/EC-80-4T-3

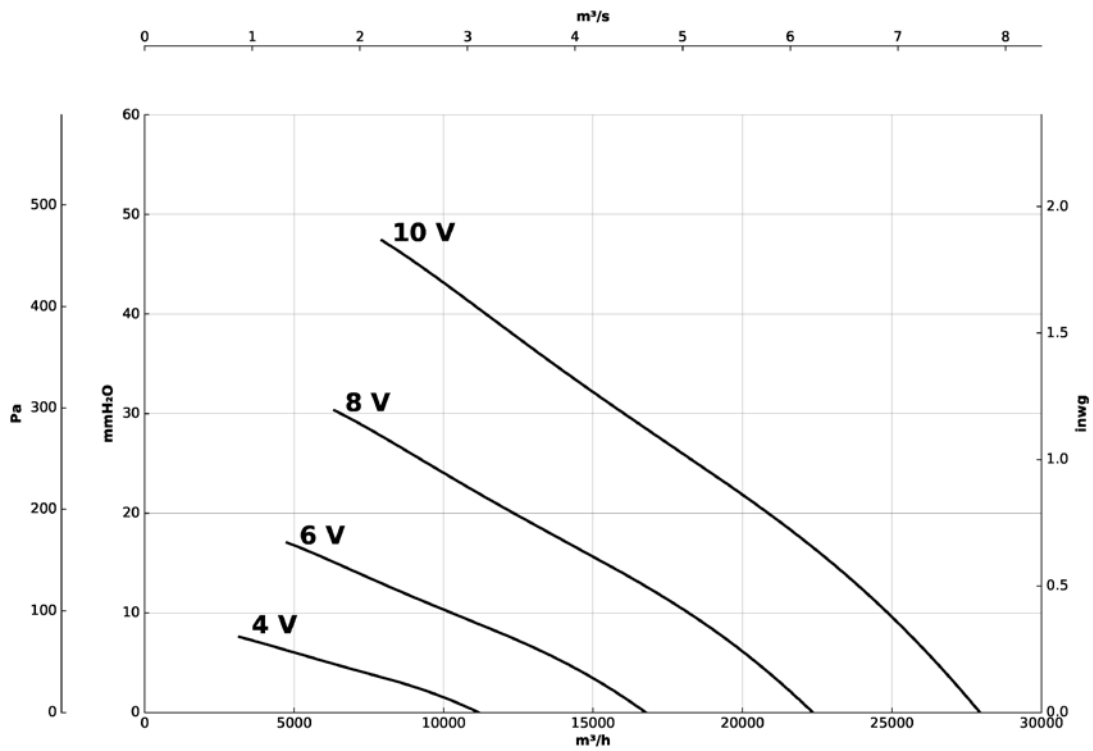

HCT/EC-80-4T-5.5

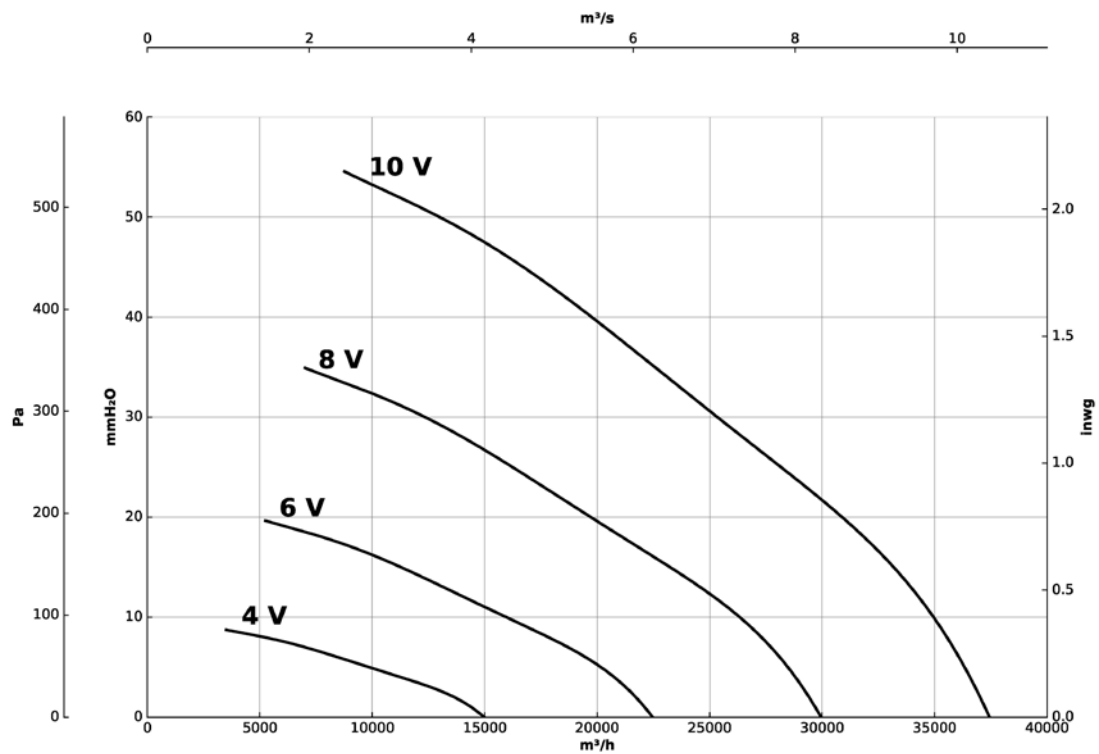

Characteristic curves

Q= Flow rate in m³/h, m³/s and cfm

Pe= Static pressure in mm H₂O, Pa and inwg

HCT/EC-90-4T-5.5

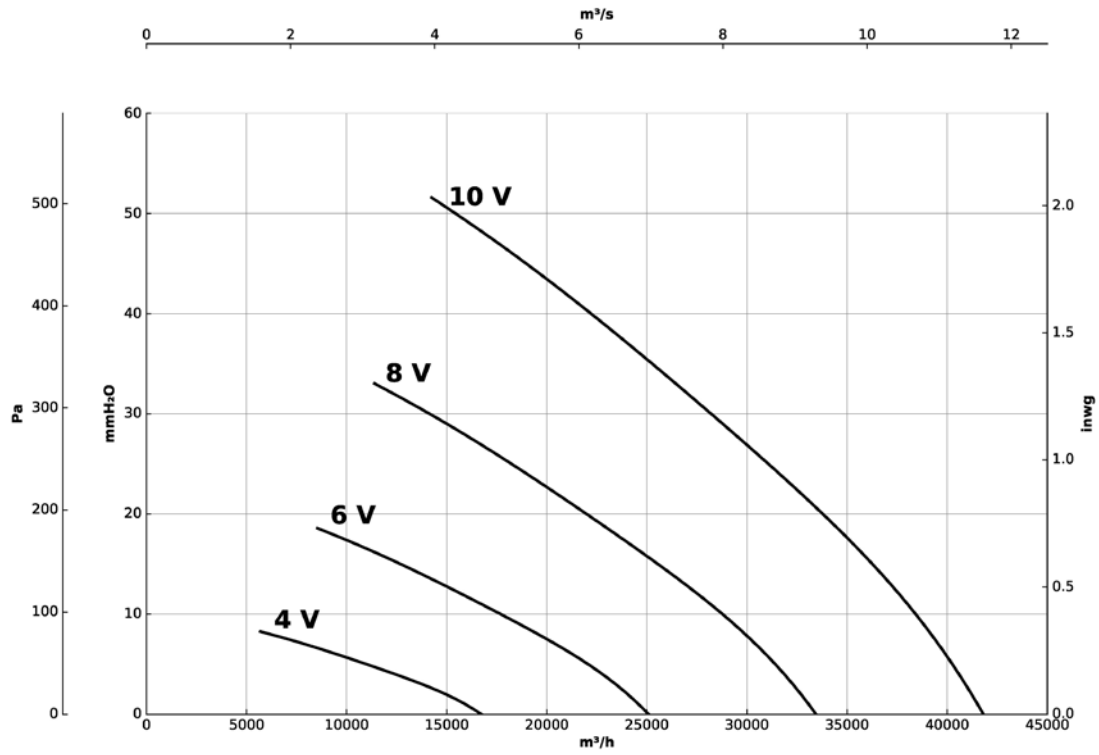

HCT/EC-90-6T-3

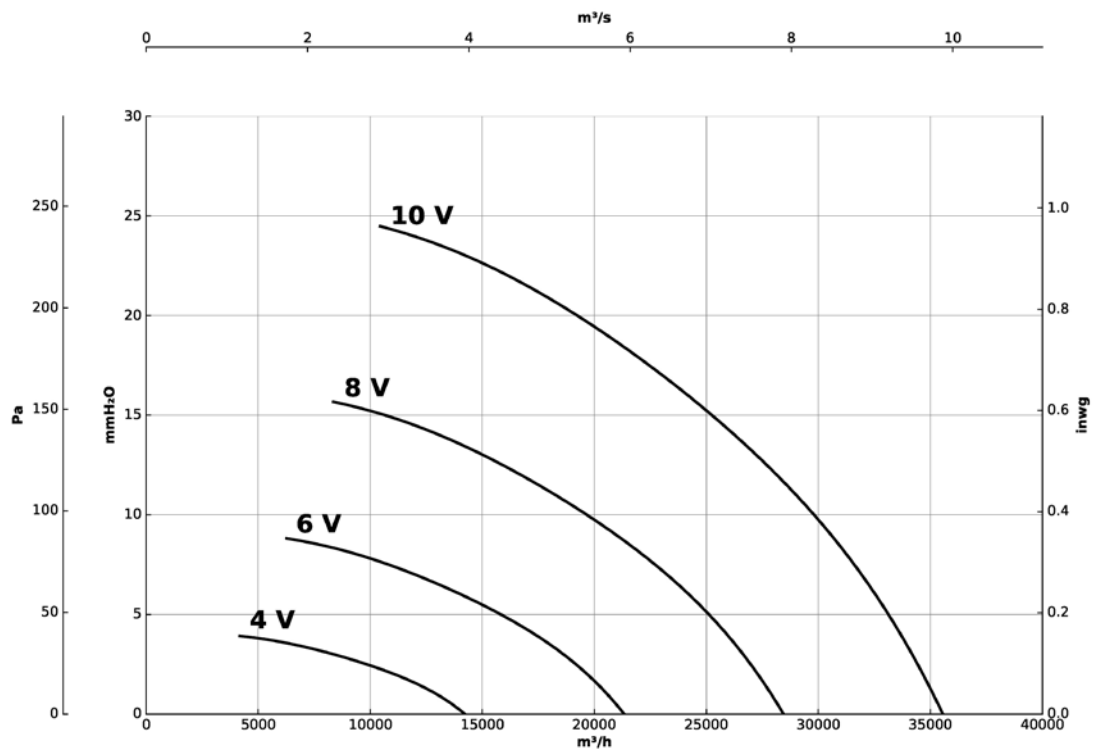

Characteristic curves

Q= Flow rate in m³/h, m³/s and cfm

Pe= Static pressure in mm H₂O, Pa and inwg

HCT/EC-100-6T-3

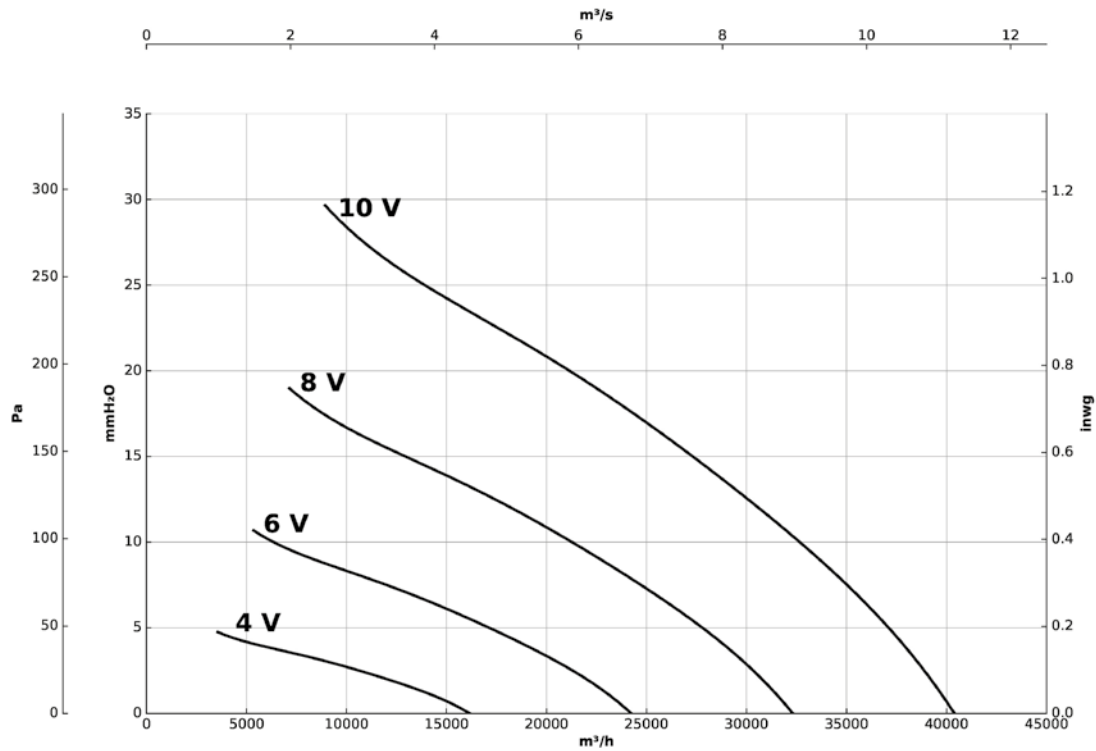

Accessories

