

VENTILATION SYSTEMS FOR TUNNELS AND UNDERGROUND WORKS

- JET FANS
- AXIAL FANS
- AUXILIARY VENTILATION

- EVACUATION ROUTES
- DAMPERS
- SILENCERS

- CONTROL AND
OPERATION



SODECA, QUALITY ASSURANCE AND SERVICE ADAPTED TO THE CLIENT

SODECA focuses its business activity on the manufacture of industrial fans, ventilation systems and smoke exhaust fans for fire protection since the company was incorporated in 1983.

Our quality procedures, certified in accordance with ISO 9001:2015, have placed the group as one of the best and most recognised fan manufacturers in the world.

The group has factories located in different countries around the world, maintaining the same EC quality standards and with teams of experienced and specialised professionals that in addition to offering ventilation equipment, also offer solutions for specific projects.



VENTILATION SYSTEMS FOR TUNNELS

SODECA has **extensive experience in manufacturing ventilation systems designed for underground infrastructures** such as tunnels, railways or undergrounds. This experience allows the company to offer comprehensive solutions to meet ventilation requirements, allowing to control the quality of the air inside the tunnel. These systems are also designed to provide emergency ventilation aimed at maintaining safe conditions in the event of fire.

The equipment manufactured by SODECA for tunnels is high quality and high performance, with a service life exceeding 20 years and adapted to the requirements of each project.

These systems perfectly integrate all the necessary components: fans, dampers, silencers, control and operating panels, sensors, etc.

Additionally, all the equipment meets national and international manufacturing (EN 12101-3), testing (ISO 13350 and ISO 5801) and quality (ISO 9001) standards and regulations.



SODECA REFERENCES

SODECA has contributed to providing ventilation solutions and ventilation systems for tunnels for emblematic international infrastructures.



Source: *City of Barcelona*

GLORIAS TUNNELS
BARCELONA (SPAIN)



UNDERGROUND L5 ERNEST LLUCH
BARCELONA (SPAIN)



VT1 2 TUNNEL
LAHTI (FINLAND)



C-17 TUNNELS
BARCELONA (SPAIN)



UNDERGROUND OF BUCHAREST
BUCHAREST (ROMANIA)



UNDERGROUND OF ANKARA (M4)
ANKARA (TURKEY)

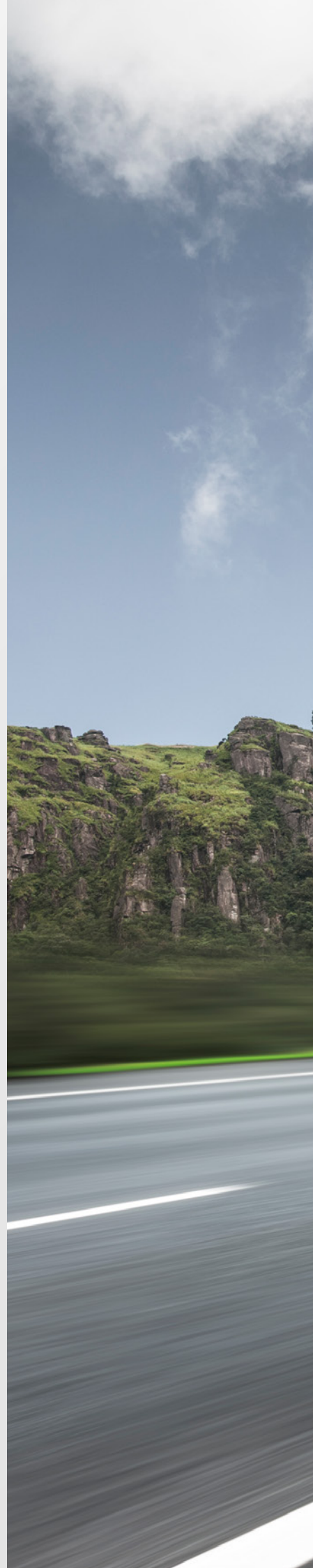



MEETING INTERNATIONAL STANDARDS

QUALITY MANAGEMENT SYSTEM

SODECA has implemented a Quality Management System that is certified in accordance with ISO 9001:2015 by Bureau Veritas, who has certified the company's ability to plan, execute and control the processes required for carrying out their work and keeping customers satisfied by delivering products manufactured using the highest quality standards.

A company committed to the reliability and warranty of their equipment installed at locations that are difficult to access and are fire safety system components.

For this reason, all critical points of the manufacturing process are inspected using a rigorous internal management control system:

- Certifications of primary materials (Sheet steel).
- Certification of the anti-corrosive treatments.
- Review of the manufacturing processes.
- Balancing of impellers.
- Checking of motor consumption.

Temperature certificates (EN 12101-3)

SODECA ventilation systems are designed with a dual purpose: daily ventilation (comfort) and emergency ventilation (in the event of fire). In the event of fire, the ventilation system controls the propagation of smoke and heat. For this reason, all the equipment is certified in accordance with EN 12101-3 by accredited and independent laboratories.

Performance tests (ISO 13500-ISO 5801)

The equipment is subjected to rigorous full scale tests to check the performance of the fan (flow and pressure, thrust, vibrations, noise levels, etc.). These tests are carried out in accordance with international standards (ISO 13500- ISO 5801).



ISO 9001:2015 certificate issued by the organisation BUREAU VERITAS.





FAN TESTS AND FACTORY ACCEPTANCE TEST (FAT)

The performance criteria of fans are essential to ensure a proper application of the ventilation system inside the tunnel. Therefore, SODECA is strict in terms of achieving equipment performances and to achieve fan performance, the company follows a test methodology and test procedures as well as standards of renown prestige such as ISO 13350 and ISO 5801.

- Motor consumption
- Flow
- Pressure
- Thrust
- Noise levels
- Vibrations

Factory Acceptance Test (FAT)

The client has the possibility of validating the performance and good operation of the equipment by carrying out a real test of the fan and supplied equipment at our installations.



RESEARCH AND DEVELOPMENT

Research and development is a continuous effort to continuously improve the equipment with the aim of **achieving increased safety, durability and low maintenance** with high levels of efficiency (ERP 2015).

SODECA ventilation systems for tunnels are tailor-made in accordance with project requirements thanks to a great team of professionals with the *know-how* and high performance technology to ensure the safety and quality of the products.



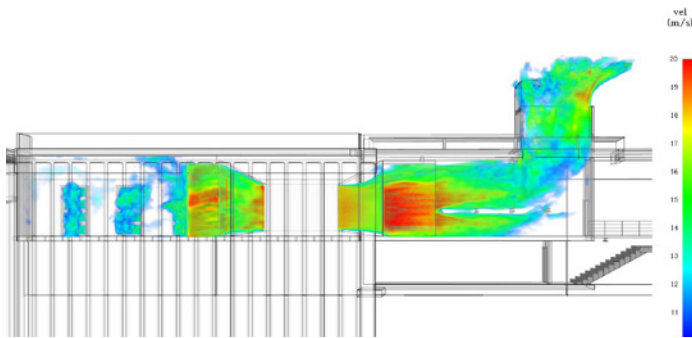

CUSTOMER SERVICE

SODECA provides **consulting and design support** as well as **personalised technical studies**. CFD studies and real smoke tests are carried out without damaging the installations.

CUSTOMER SUPPORT SOLUTIONS: QUICKFAN AND 3D MODELS



QuickFan is the software used for making calculations and designing ventilation projects.

Selecting the most suitable product for your ventilation installation is now easier than ever.

Through the projects module for QuickFan and by downloading the designs in CAD 3D or REVIT, you can design ventilation projects, make calculations and obtain full technical reports in just a few minutes.

FANS IN **BIM** FORMAT FOR YOUR PROJECTS



Saving time and resources when managing projects is possible thanks to the BIM system for more than 5,200 fan models. This format adds additional characteristics and technical information to the model and improves how the execution of a project is monitored. BIM, one step further in project management.

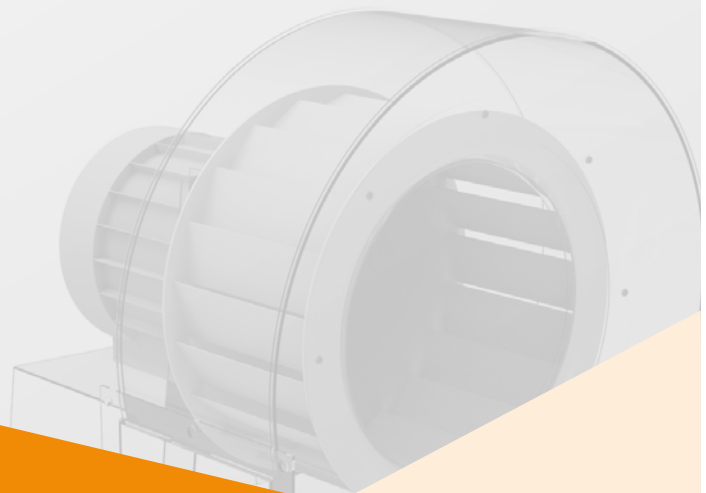

*Make it easy with
QuickFan!*





VENTILATION SYSTEMS FOR **TUNNELS AND UNDERGROUND CONSTRUCTION PROJECTS**

TUNNELS
MINING
STATIONS
EVACUATION ROUTES
ACCESSORIES



TUNNELS

It is essential that reliable ventilation systems are used to provide safety for the user throughout the years.

Tunnel ventilation may be natural or forced and in the latter case, fans must be installed to generate the proper air movement to maintain safe conditions in comfort mode as well as in event of an emergency.

FUNCTIONS OF THE VENTILATION FOR TUNNELS

Ventilation system in **comfort mode** (healthy air):

- Maintains health conditions such as adequate temperature or humidity.
- Supplies fresh and clean air from the outside.
- Extracts air pollutants.

Ventilation system in **emergency mode** (in the event of fire):

- Provides a safe environment.
- Exhaust of smoke and heat in the event of fire.
- Enables to maintain personnel evacuation routes clear and safe.
- Safe and automated control system for activating emergency manoeuvres.

VENTILATION SYSTEMS

Ventilation systems **may be configured based on different key elements** such as the type of tunnel, length, slope or traffic volume:

LONGITUDINAL VENTILATION

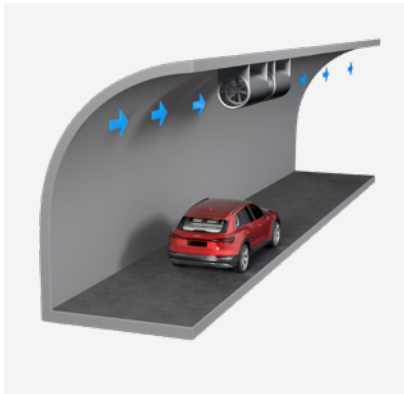

TRANSVERSE VENTILATION

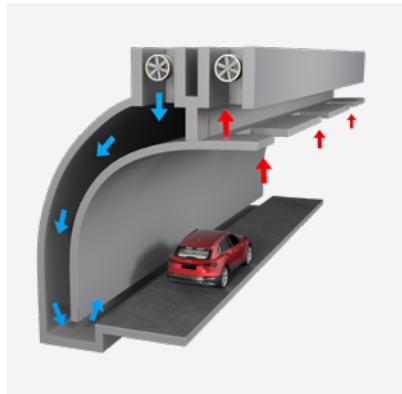

SEMI-TRANSVERSE VENTILATION

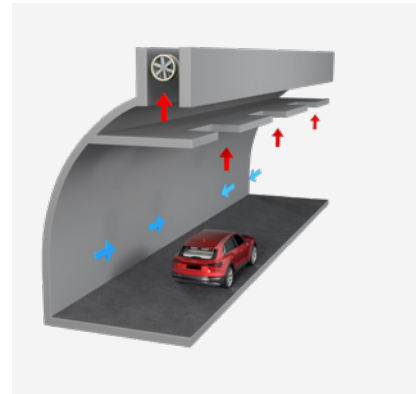

SOLUTIONS

VENTILATION FOR TUNNELS



THT/IMP-TM



THT-TM



THT/IMP



CI



THT/WALL

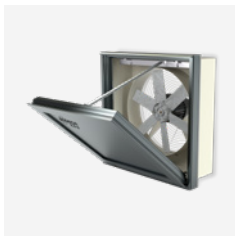

THT/WALL-F

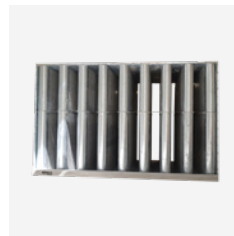

RECTANGULAR
SILENCERS



CONTROL
AND MANOEUVRE



DAMPER



SOLUTIONS WITH JET FANS

Ventilation systems for tunnels with jet fans are the most widely used. Kinetic energy is used to remove stale internal air (gases and smoke generated by vehicles in road tunnels, railway and underground tunnels).

These can be unidirectional or reversible fans. Unidirectional type fans are designed to optimise performance in one direction (forward), while reversible fans provide the same performance but in both directions.

Since the environmental conditions inside some tunnels may be highly corrosive, the material used for manufacturing these fans must be appropriate and with anti-corrosive finish in order to extend their service life.

JET FANS FOR TUNNELS

Fans especially designed for tunnel ventilation.

- Max. diameter: 450 mm - 1800 mm.
- Max. flow: 360,000 m³/h (100 m³/s).
- Max. thrust: 2850 N.
- Resistance to fire: F200 - F300 - F400.

Materials and finish:

- Carbon steel with epoxy paint protective coating.
- Galvanised steel.
- Stainless steel.

Electric motor:

- Extremely robust electric motors.
- Resistant to temperatures: F400 - F300 - F200.
- Class H protection and IE3 efficiency category.
- Specific bearings for operating between 20,000 h and 100,000 hours.

Impeller:

- Reversible.
- High efficiency.
- Temperature resistant.
- Adjustable blades.
- Static and dynamic balancing in accordance with ISO 1940 (G-2.5).

Silencers:

- Reduction in noise levels.
- Installed on both sides of the casing.
- Manufactured using perforated plate inside.
- High density and temperature resistant rock wool.

ANCHORING AND SAFETY SYSTEMS

These fans are mounted to the ceiling of the tunnel using anchoring systems designed and calculated specifically for each project.

The anchoring systems are equipped with anti-vibration units that are selected according to the fan's weight and thrust.

Several anchoring systems are used, adapted to the specific conditions of each tunnel.

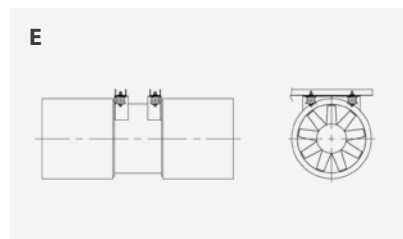
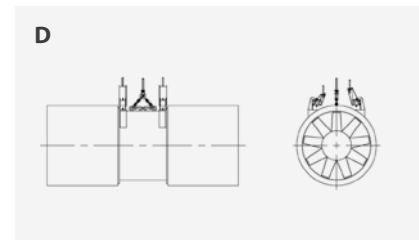
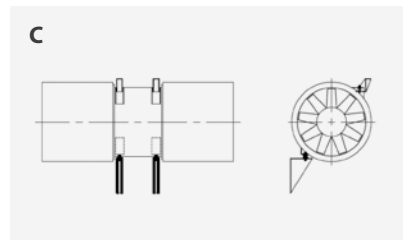
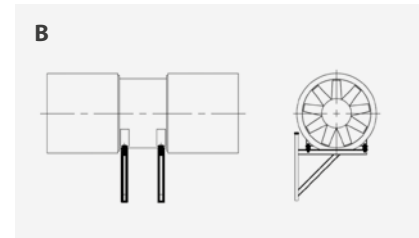
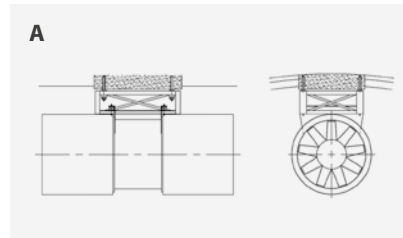

ACCESSORIES

- Temperature sensors in windings and bearings (PT100, PTC)
- Vibration sensors
- Heating elements
- Airflow sensors
- Deflectors
- Grilles
- Power switches

PRODUCT NOMENCLATURE

THT/IMP	O	-	UNI	-	38	-	2/4T	-	1,5	-	F-400	-	TM
THT/IMP: Jet fans with a long reach	Design C: Circular casing O: Painted casing L: Galvanised sheet steel casing LS: Small-sized casing		Airflow direction UNI: One-way REV: Reversible		Impeller diameter in cm.		Number of motor poles 2 = 2900 r/min 50 Hz 4 = 1400 r/min 50 Hz 6 = 900 r/min 50 Hz 8 = 750 r/min 50 Hz 12 = 500 r/min 50 Hz T = Three-phase		Motor power (CV)		F-200: Certified 200 °C / 2 h. F-300: Certified. Tested for 300 °C / 2 h. F-400: Certified 400 °C / 2 h.		Tunnel and mining



AXIAL FAN SOLUTIONS

Axial fans are essential **for renewing indoor air and for extracting smoke in the event of fire**. They are installed in ventilation shafts that connect the tunnel with the outside, allowing to supply fresh air inside the tunnel.

- High performance fans in terms of quality and reliability.
- Manufactured in accordance with European standards (EC marking and EN 12101-3).
- Especially designed for tunnels.
- Easy to maintain.
- Fully reversible fans.
- Horizontal or vertical installation.



Axial fan with guides to generate increased pressure (impeller not mounted)

AXIAL FANS FOR TUNNELS

- Max. diameter: 3,550 mm
- Max. flow: 1,000,000 m³/h (277 m³/s).
- Max. pressure: 4,000 Pa.
- Temperature: 200 °C 2 h / 300 °C 2 h / 400 °C 2 h.
- Reversible.

Motors:

- Class H and IP-55 (IP 65) protection.
- IE3 efficiency or greater 50 Hz - 60 Hz.

- External junction box.
- Vibration and temperature sensors.

Material options:

- Damper made of carbon steel with epoxy paint protective coating.
- Damper made of galvanised steel.
- Damper made of stainless steel.

PRODUCT NOMENCLATURE

THT	-	160	-	4T	-	110	-	F-400	-	TM
↓		↓		↓		↓		↓		↓
THT: Cylindrical axial extract fans 400 °C/2 h, 300 °C/2 h and 200 °C/2 h. THT/ATEX: Cylindrical axial extract fans 400 °C/2 h, 300 °C/2 h and 200 °C/2 h with ATEX certification.		Impeller diameter in cm.		Number of motor poles 2 = 2900 r/min 50 Hz 4 = 1400 r/min 50 Hz 6 = 900 r/min 50 Hz 8 = 750 r/min 50 Hz 12 = 500 r/min 50 Hz T = Three-phase		Motor power (CV)		F-200: Certified 200 °C / 2 h. F-300: Certified. Tested for 300 °C / 2 h. F-400: Certified 400 °C / 2 h. CAT3: With ATEX Category 3 Ex II3G certification.		Tunnel and mining

ACCESSORIES

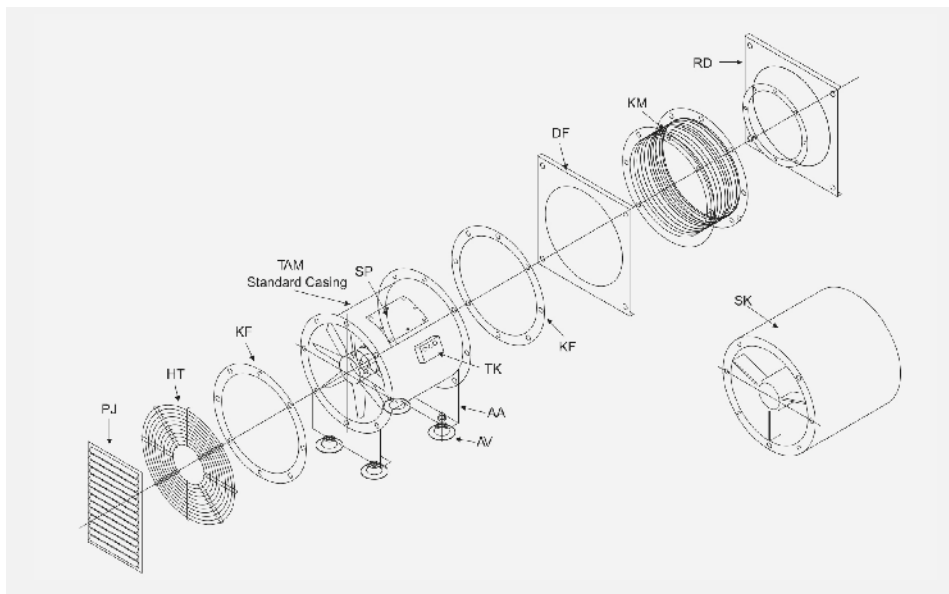

- PJ:** Fixed blade grille
- HT:** Protective grille
- KF:** Connection flange
- SP:** Access door
- AV:** Anti-vibration system
- AA:** Mounting feet
- TK:** Terminal board
- DF:** Connection frame
- KM:** Flexible connector



MINING

Fans especially designed **to operate in dusty environments and easy to maintain**. Ventilation during the construction phase of tunnels or in mining requires very high pressures with an average or high airflow.

SODECA provides a wide range of solutions for mining with **simple stage (SS) fans** that generate

high pressures and **multi-stage (MS) fans** that support very high pressures. Centrifugal fans are also supplied with high pressures and flows.

These fans are manufactured in accordance with the regulations and requirements of the project with the aim of maintaining high levels of safety for the users.

JET FANS FOR MINING (STANDARD)

Simple stage (SS) fan:

- Max. diameter: 315 mm – 1,800 mm.
- Max. flow: 360,000 m³/h (100 m³/s).
- Max. pressure: 3,000 Pa.

Multi-stage (MS) fan:

- Max. diameter: 315 mm – 1,800 mm.
- Max. flow: 360,000 m³/h (100 m³/s).
- Total pressure: 5,000 Pa.

Materials and finish:

- Carbon steel with epoxy paint protective coating.
- Galvanised steel.
- Stainless steel.



PRODUCT NOMENCLATURE

THT	-	UNI	-	120	-	2/4T	-	SS	-	1x75	-	F-400	-	TM
↓		↓		↓		↓		↓		↓		↓		↓
THT: Cylindrical axial fans		Airflow direction UNI: One-way REV: Reversible		Impeller diameter in cm.		Number of motor poles 2 = 2900 r/min 50 Hz 4 = 1400 r/min 50 Hz 6 = 900 r/min 50 Hz 8 = 750 r/min 50 Hz 12 = 500 r/min 50 Hz		T = Three-phase SS: Simple stage MS: Multi-stage		Number of motors. Motor power (CV).		F-200: Certified 200 °C / 2 h. F-300: Certified. Tested for 300 °C / 2 h. F-400: Certified 400 °C / 2 h.		Tunnel and mining



STATIONS

Ventilation systems at stations (train and underground) are installed in common areas (lobbies, platforms, etc.), in control and operation rooms (operator worker areas) and in technical rooms.

FUNCTIONS OF THE VENTILATION FOR STATIONS

Ventilation system in **comfort mode** (healthy air):

- Provides continuous airflow in comfort mode.
- Maintains suitable health conditions such as temperature or humidity.
- Dilutes thermal loads.
- Extracts air pollutants.
- Improves energy efficiency.
- Incorporates an automatic control system for activating comfort ventilation manoeuvres.

Ventilation system in **emergency mode** (in the event of a fire):

- Provides a safe environment.
- Installation of high temperature resistant equipment (F400, F300).
- Exhausts smoke and heat in the event of fire.
- Enables to maintain personnel evacuation routes clear and safe.
- Safe and automated control system for activating emergency manoeuvres.

SOLUTIONS

VENTILATION FOR STATIONS



SV



SVE/PLUS



HEPT



CJHCH

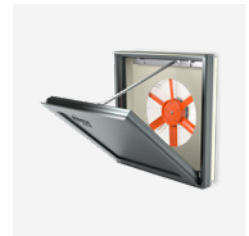

WALL/AXIAL

VENTILATION, FILTRATION AND PURIFICATION



AIRDOG



SV/FILTER-CG



CJK/FILTER/EC



UPM/EC



UPA

OVERPRESSURE VENTILATION (F400)



THT



THT/CL



THT/WALL



THT/WALL-F



THT/HATCH

VENTILATION FOR TECHNICAL ROOMS



HEPT

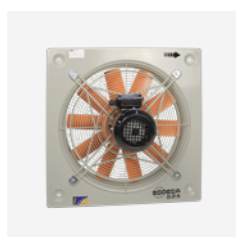

HC



HCH



HCT



CJHCH

CONTROL AND POWER

The functionality of the control and power panels is to turn on, regulate and control the ventilation in comfort mode and emergency mode. The panels are equipped with all the components and protections required for managing and controlling the ventilation system in accordance with the requirements of the project.

- Tailor-made solutions in accordance with the client's requirements.
- Plug&Play system.
- Connection to a BMS system via MODBUS.
- Integration with the SCADA system.
- PLC with inputs and outputs for different signals.
- Can be used with a speed controller or starter.
- Manoeuvres programmed according to the specifications of the project.



SCADA & MCC

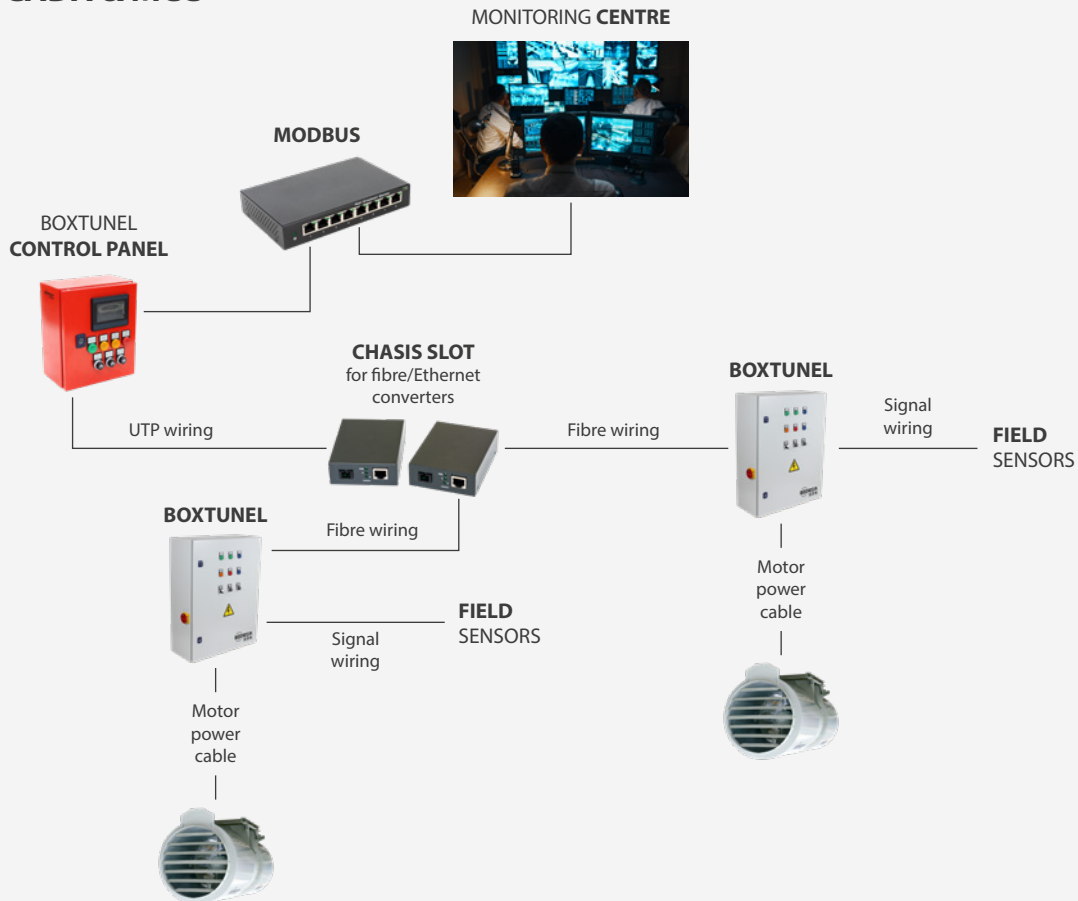

FIELD SENSORS







EVACUATION ROUTES

Pressurisation control systems prevent smoke from entering escape routes through air overpressure. If the doors are opened or in the event of air leaks, the system reacts by increasing the flow rate. This guarantees that the escape routes are always free of smoke in an emergency situation.

The following are considered escape routes: evacuation tunnels, interconnecting tunnels, corridors, staircases, lifts or for example, lobbies.

FUNCTIONS OF THE VENTILATION SYSTEM FOR EVACUATION ROUTES

The pressurisation system:

- **Allows automatically controlling the flow** when the door is open (speed criteria) **and maintain a minimum differential pressure** (50 Pa) in cases where the door is closed in accordance with the requirements set out in European standard EN 12101-6.
- Equipped with all the **components required** for proper operation in accordance with regulation EN 12101-6 (fan, pressure sensor, hatch, speed controller, PLC, etc.).
- They are supplied integrated and ready for operation (**Plug&Play system**).
- The system incorporates an **activation in safe mode** when a fire alarm signal is activated and safe mode of operation when the doors are open due to a overpressure condition.
- The system is connected to the BMS - Building Management System or SCADA and may get the status of all the equipment via a remote connection depending on the model. Additionally, a remote communications panel may be added for use by the fire department or other users.
- The control panel incorporates status indicator lights and automatic or manual system power selector.
- A motorised hatch and smoke detector may be used to manage air intake.

PRESSURISATION IN STAIRCASES, LOBBIES AND EVACUATION ROUTES

BASIC		ADVANCED	FULL RANGE		
KIT SOBREPRESIÓN	PRESSKIT	KIT BOXSMART KIT BOXSMART II	KIT BOXPDS KIT BOXPDS II	HATCH PDS	
Applications					
Staircases, corridors, lifts, lobbies	Lobbies	Staircases, corridors, lifts, lobbies	Staircases, corridors, lifts, lobbies	Staircases, corridors, lifts, lobbies	
Installation					
Roofs, interiors	Only lobbies	Roofs, interiors	Roofs, interiors	Roofs	
Inlet hatches management					
-	-	Yes	Yes	Yes	
Leak detection					
-	-	-	Yes	Yes	
Inlet smoke detection					
-	-	-	Yes	Yes	
Compatible with fire cabinets					
-	-	Yes	Yes	Yes	
Self-calibration					
-	-	-	Yes	Yes	
Connection to BMS systems					
-	Yes	Yes	Yes	Yes	
Spare fan					
Yes	-	Yes	Yes	-	
Reversible for smoke extraction					
-	-	Yes	Yes	Yes	
Control of multiple independent lobbies					
-	-	-	Yes	Yes	
Built-in control panel					
-	-	Yes	Yes	Yes	
Option of daily ventilation					
-	-	Yes	Yes	Yes	
Operates in the event of loss of activation signal					
-	Yes	Yes	Yes	Yes	

SOLUTIONS

BASIC PRESSURISATION SYSTEMS



KIT SOBREPRESIÓN



BOXPRES PLUS



BOXPRES PLUS II



KIT BOXPRES PLUS



PRESSKIT

ADVANCED PRESSURISATION SYSTEMS



KIT BOXSMART



KIT BOXSMART EC



KIT BOXSMART FLAP



BOXSMART



BOXSMART II

FULL RANGE PRESSURISATION SYSTEMS



KIT BOXPDS



KIT BOXPDS II



HATCH PDS

ACCESSORIES

SILENCERS

Silencers are used to reduce the noise generated by the fan and air passing at high speed. Units with cells guarantee a better acoustic attenuation of critical frequencies of the noise emitted when the equipment is operating.

They are comprised of:

- Casing with centre and perimeter reinforcements.
- Cells with an aerodynamic profile and rock wool.
- Fire resistant rock wool.
- Low load loss.
- Acoustic attenuation and power sound of the noise generated by the air (in compliance with ISO-7235).

Dimensions:

- Thickness of the cells: 100, 200, 230 mm.
- Standard sizes: up to 2400 × 1800 × 1500 mm.
- Large size: tailor made in accordance with requirements.

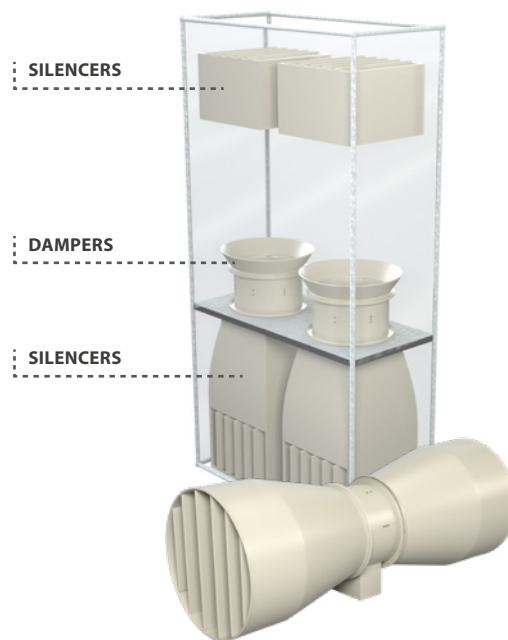

DAMPERS

MPA-TM series dampers are resistant to high temperatures (400 °C / 2 h). Especially designed for installation in the ventilation system and extracting smoke in underground infrastructures.

MPA-TM dampers are:

- Resistant to extreme operating conditions such as in environments with dust and oxide.
- Robust even against train piston effect and high temperatures.
- High level of air-tightness to prevent leaks.
- High operating pressures (up to 5,000 Pa).

Actuation:

- Single-phase or three-phase servomotor.

- Temperature resistant.
- On/off or adjustable.

Dimensions:

- Standard: up to 2000 * 2000 mm.
- Large size: modular in accordance with requirements.

Finish options:

- Hatch made of carbon steel with epoxy paint protective coating.
- Hatch made of galvanised steel.
- Hatch made of stainless steel.

The environmental conditions inside some tunnels may be highly corrosive, therefore, the material used for manufacturing these fans must be appropriate and anti-corrosive finish in order to extend their service life.

