

PF/ATEX

ATEX-certified, Plug Fan type high efficiency centrifugal fans for air treatment applications



Marking:

Ex eb: Ex II 2G Ex eb IIB T3 Gb

Ex db: Ex II 2G Ex db IIB T4 Gb

Ex tb: Ex II 2D Ex tb IIIC T135 °C Db

Ex tc: Ex II 3D Ex tc IIIB T135 °C Dc

Identification no.: LOM 20.554U-C



ATEX-certified, Plug Fan type high efficiency centrifugal fans for air treatment applications, with increased safety Ex II 2G Ex eb, flameproof Ex II 2G Ex db or dust ignition proof Ex II 2D tb or Ex II 3D tc motor for working in explosive atmospheres containing dust or gas.

Fan:

- Galvanised sheet steel structure.
- Backward curved impeller made of sheet steel.
- Non-sparking inlet ring made of copper.
- Complete with a pressure measurement connection point for optional automatic flow and pressure control.
- Vertical execution not available for sizes 1871 and 2180.
- A frequency variator is necessary for work points that require rpm other than the motor's nominal ones.

Motor:

- Class F motors with ball bearings and with ATEX certification, increased safety Ex eb or flameproof Ex db or dust ignition proof Ex tb or Ex tc.
- Motors with built-in PTC.
- Three-phase 230/400 V (up to 4 kW) and 400/690 V (powers greater than 4 kW).
- Maximum temperature of air to be carried: -25 °C +60 °C.

Finish:

- Anti-corrosive in galvanized steel sheet.

On request:

- Special windings for different voltages and frequencies.
- ATEX construction for different categories.

Order code



PF/ATEX: ATEX-certified, Plug Fan type high efficiency centrifugal fans for air treatment applications

Marking:

II 2G Ex h IIB T3 Gb

II 2G Ex h IIB T4 Gb

II 2D Ex h IIIC T135°C Db

II 3D Ex h IIB T135°C Dc

Execution:
H=Horizontal
V=Vertical

Impeller size

Number of motor poles
2=3000 r/min 50 Hz
4=1500 r/min 50 Hz
6=1000 r/min 50 Hz

T = Three-phase

Motor power (HP)

Ex eb: increased safety for zone 1 and 2
Ex db: non-sparking for zone 1 and 2
Ex tb: for zone 21 and 22
Ex tc: for zone 22

Accessories



SI-PRESIÓN



INT/ATEX



VSD3/A-RFT
- VSD1/A-RFM



AET



RPA



B



BD

925

Characteristic curves

Q= Flow rate in m³/h, m³/s and cfm

Pe= Static pressure in mm H₂O, Pa and inwg

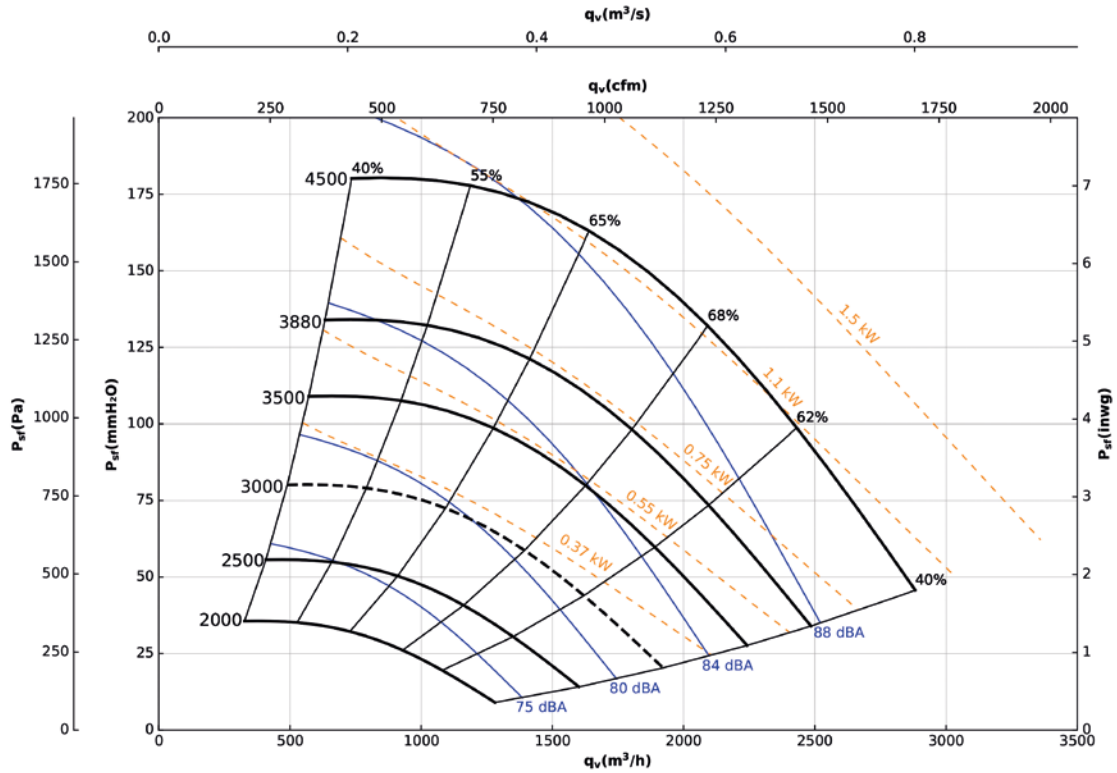

Technical characteristics

Model	Nominal speed ¹ (r/min)	Maximum admissible current (A)		Installed power (kW)	Max. speed (r/min)	Maximum frequency (Hz)	Approx. weight (Kg)	
		230V	400V				Ex eb	Ex db
PF/ATEX-925-2T-0.5	2770	2.08	1.20	0.37	3000	54	22	23
PF/ATEX-925-2T-0.75	2710	2.94	1.70	0.55	3500	65	20	22
PF/ATEX-925-2T-1	2820	3.46	2.00	0.75	3880	69	21	22
PF/ATEX-925-2T-1.5	2850	4.50	2.60	1.1	4420	78	23	24
PF/ATEX-925-2T-2	2800	6.24	3.60	1.5	4500	80	24	29

¹ The indicated values are determined to 50 Hz motors.

925

Dimensions mm

Horizontal

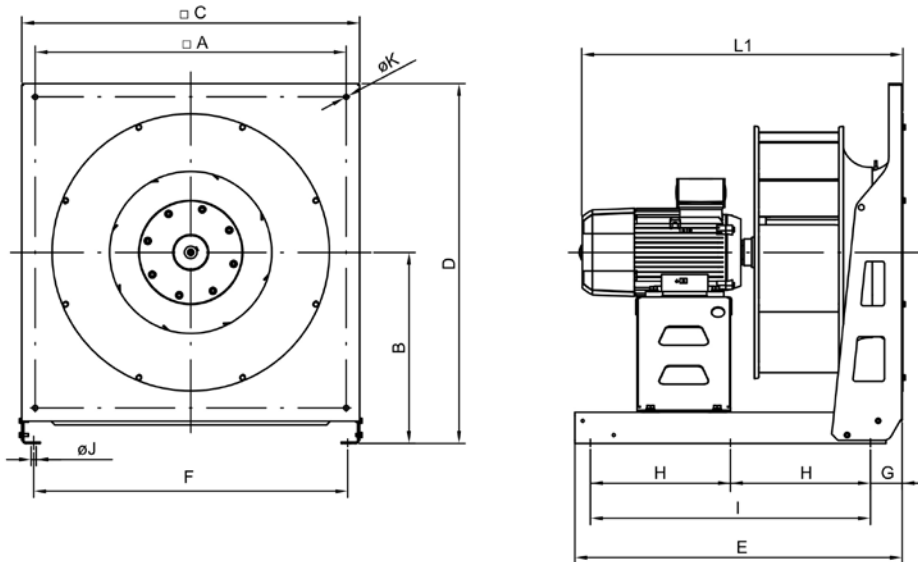

	□A	B	□C	D	E	F	G	H	I	ØJ	ØK	L1
PF-925-2T-0.5	350	215	400	415	405	345	70	-	300	9	9	400
PF-925-2T-0.75	350	215	400	415	405	345	70	-	300	9	9	400
PF-925-2T-1	350	215	400	415	405	345	70	-	300	9	9	433
PF-925-2T-1.5	350	215	400	415	405	345	70	-	300	9	9	433
PF-925-2T-2	350	215	400	415	405	345	70	-	300	9	9	441

Vertical

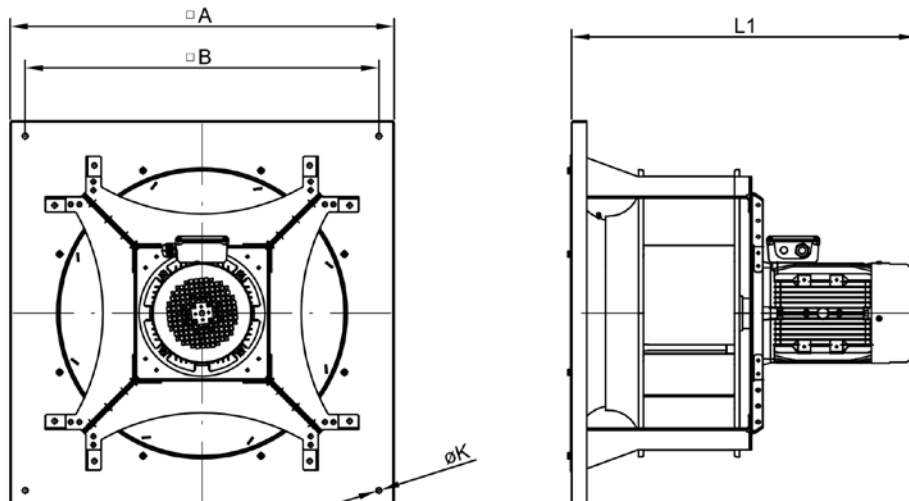

	□A	□B	ØK	L1
PF-925-2T-0.5	367	400	11	400
PF-925-2T-0.75	367	400	11	400
PF-925-2T-1	367	400	11	433
PF-925-2T-1.5	367	400	11	433
PF-925-2T-2	367	400	11	441

1028

Characteristic curves

Q= Flow rate in m³/h, m³/s and cfm

Pe= Static pressure in mm H₂O, Pa and inwg

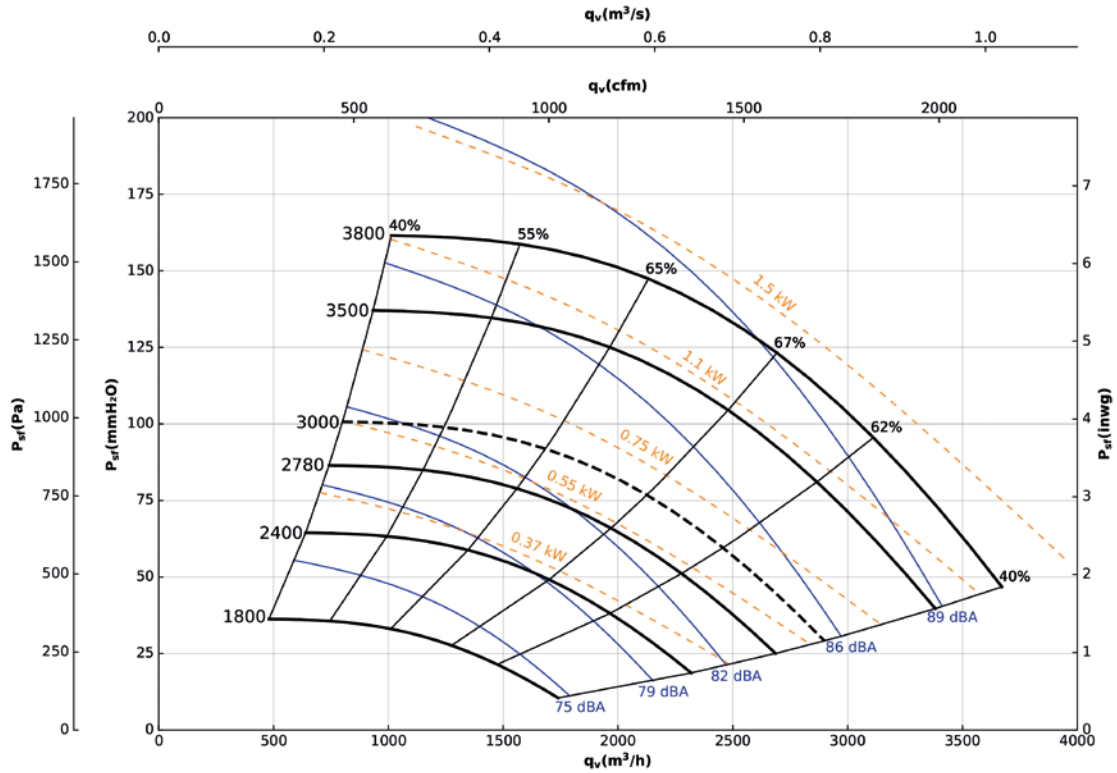

Technical characteristics

Model	Nominal speed ¹ (r/min)	Maximum admissible current (A)		Installed power (kW)	Max. speed (r/min)	Maximum frequency (Hz)	Approx. weight (Kg)	
		230V	400V				Ex eb	Ex db
PF/ATEX-1028-2T-0.75	2710	2.94	1.70	0.55	2780	51	21	23
PF/ATEX-1028-2T-1	2820	3.46	2.00	0.75	3080	55	23	24
PF/ATEX-1028-2T-1.5	2850	4.50	2.60	1.1	3500	61	24	25
PF/ATEX-1028-2T-2	2800	6.24	3.60	1.5	3800	68	26	31
PF/ATEX-1028-4T-0.5	1370	2.60	1.50	0.37	2400	88	23	25

¹ The indicated values are determined to 50 Hz motors.

1028

Dimensions mm

Horizontal

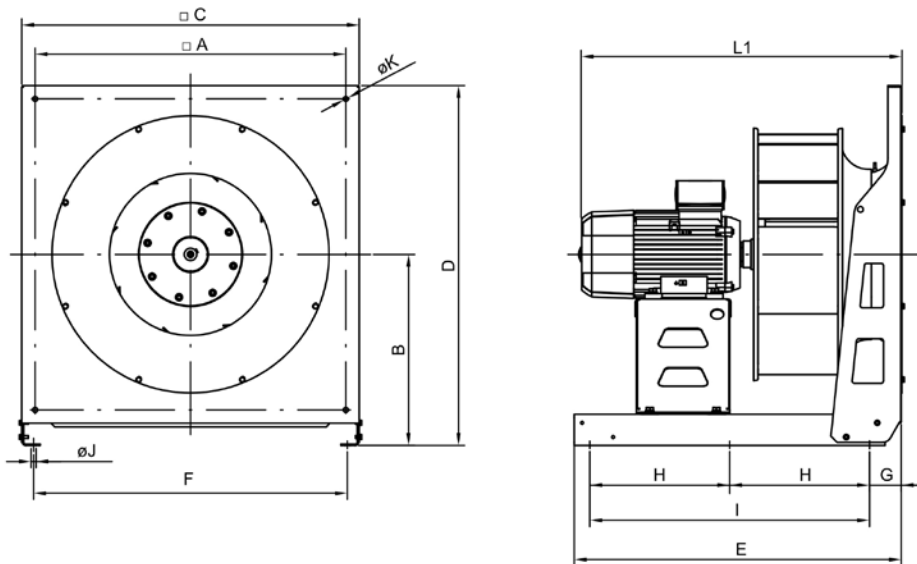

	□A	B	□C	D	E	F	G	H	I	ØJ	ØK	L1
PF-1028-2T-0.75	375	215	400	415	405	345	70	-	300	9	9	417
PF-1028-2T-1	375	215	400	415	405	345	70	-	300	9	9	450
PF-1028-2T-1.5	375	215	400	415	405	345	70	-	300	9	9	450
PF-1028-2T-2	375	215	400	415	405	345	70	-	300	9	9	458
PF-1028-4T-0.5	375	215	400	415	405	345	70	-	300	9	9	417

Vertical

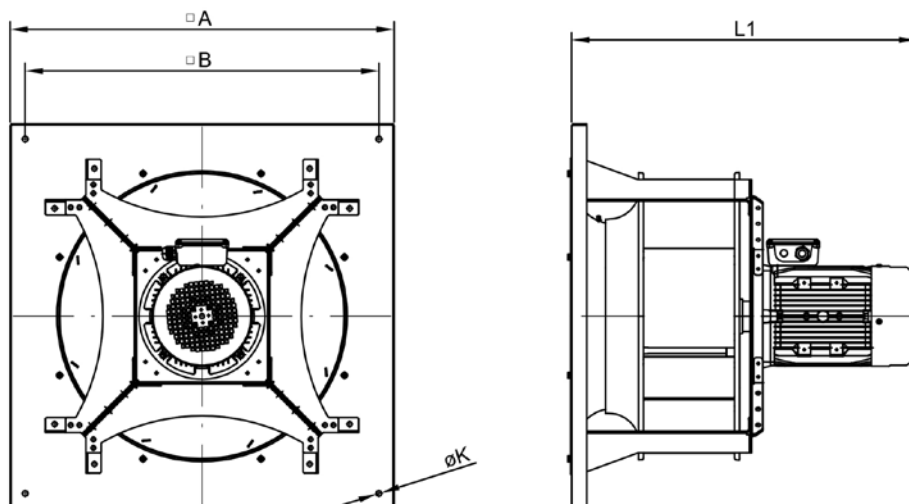

	□A	□B	ØK	L1
PF-1028-2T-0.75	390	420	11	417
PF-1028-2T-1	390	420	11	450
PF-1028-2T-1.5	390	420	11	450
PF-1028-2T-2	390	420	11	458
PF-1028-4T-0.5	390	420	11	417

1031

Characteristic curves

Q= Flow rate in m³/h, m³/s and cfm

Pe= Static pressure in mm H₂O, Pa and inwg

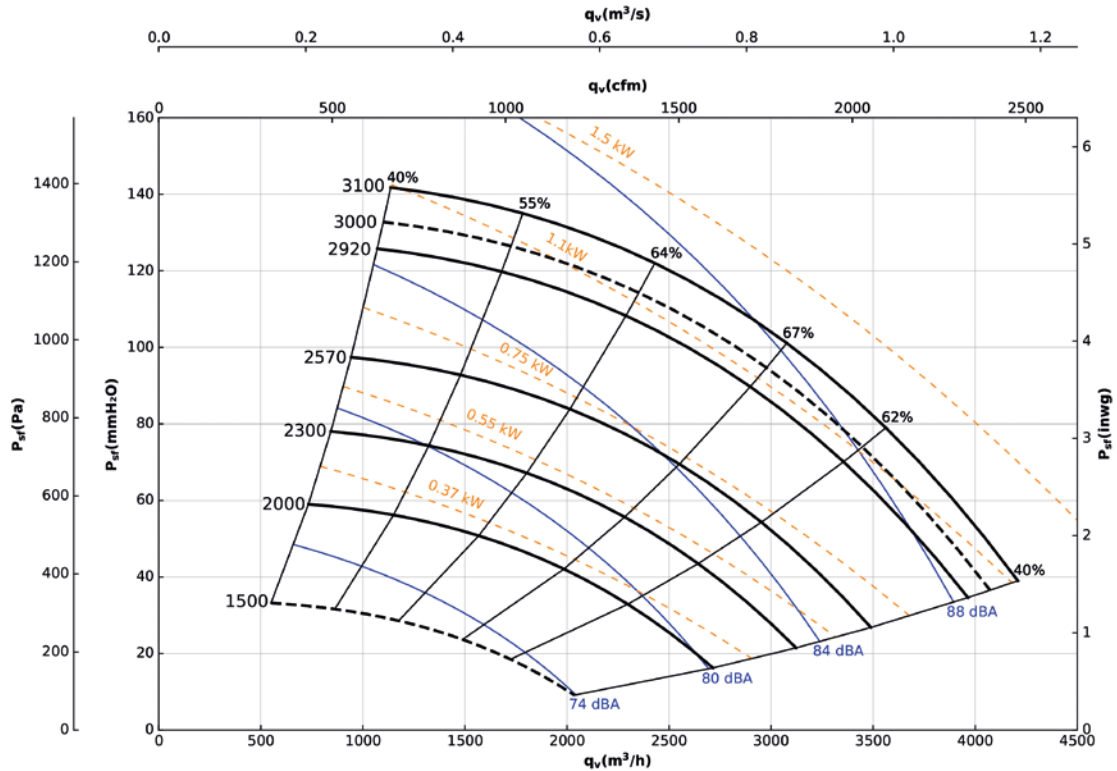

Technical characteristics

Model	Nominal speed ¹ (r/min)	Maximum admissible current (A)		Installed power (kW)	Max. speed (r/min)	Maximum frequency (Hz)	Approx. weight (Kg)	
		230V	400V				Ex eb	Ex db
PF/ATEX-1031-2T-1.5	2850	4.50	2.60	1.1	2920	51	25	26
PF/ATEX-1031-2T-2	2800	6.24	3.60	1.5	3100	55	27	32
PF/ATEX-1031-4T-0.5	1370	2.60	1.50	0.37	2000	73	25	27
PF/ATEX-1031-4T-0.75	1410	2.94	1.70	0.55	2300	82	28	31
PF/ATEX-1031-4T-1	1410	3.81	2.20	0.75	2570	91	26	28

¹ The indicated values are determined to 50 Hz motors.

1031

Dimensions mm

Horizontal

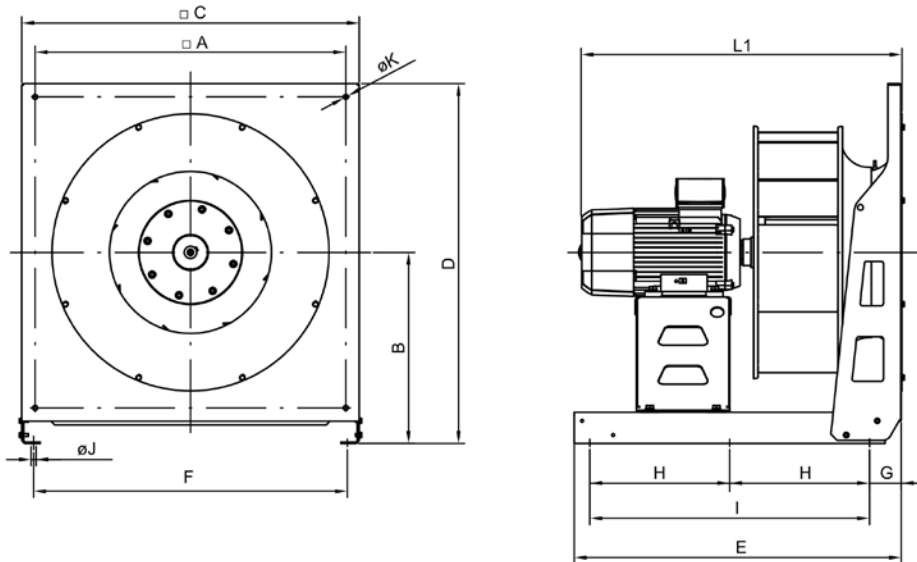

	□A	B	□C	D	E	F	G	H	I	ØJ	ØK	L1
PF-1031-2T-1.5	375	215	400	415	505	345	70	-	400	9	9	460
PF-1031-2T-2	375	215	400	415	505	345	70	-	400	9	9	471
PF-1031-4T-0.5	375	215	400	415	505	345	70	-	400	9	9	428
PF-1031-4T-0.75	375	215	400	415	505	345	70	-	400	9	9	460
PF-1031-4T-1	375	215	400	415	505	345	70	-	400	9	9	460

Vertical

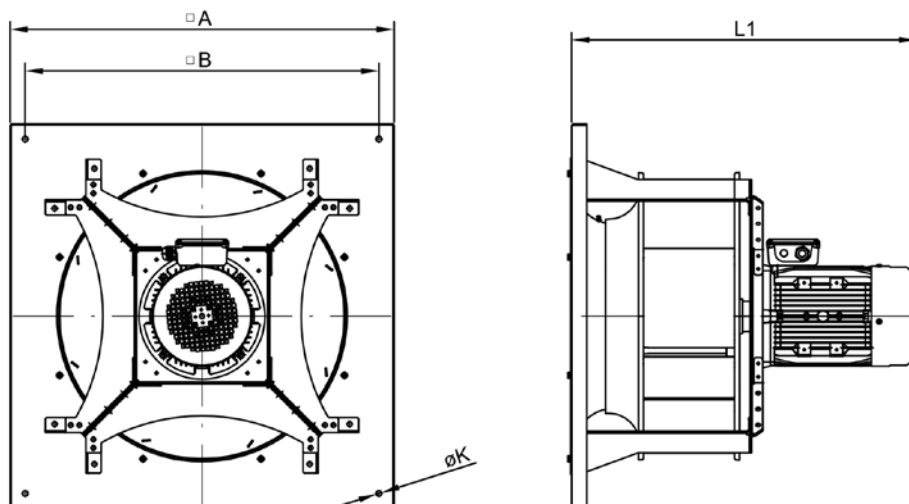

	□A	□B	ØK	L1
PF-1031-2T-1.5	434	470	11	460
PF-1031-2T-2	434	470	11	471
PF-1031-4T-0.5	434	470	11	428
PF-1031-4T-0.75	434	470	11	460
PF-1031-4T-1	434	470	11	460

1135

Characteristic curves

Q= Flow rate in m³/h, m³/s and cfm

Pe= Static pressure in mm H₂O, Pa and inwg

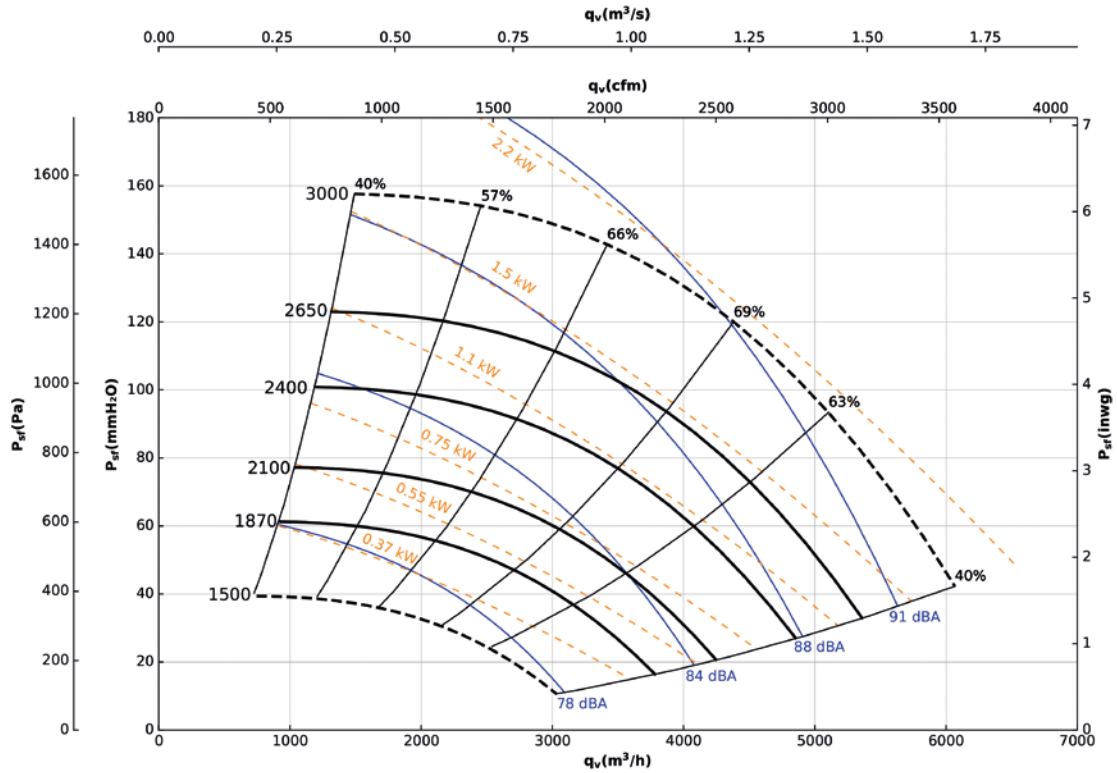

Technical characteristics

Model	Nominal speed ¹ (r/min)	Maximum admissible current (A)		Installed power (kW)	Max. speed (r/min)	Maximum frequency (Hz)	Approx. weight (Kg)	
		230V	400V				Ex eb	Ex db
PF/ATEX-1135-2T-3	2860	8.66	5.00	2.2	3000	52	28	31
PF/ATEX-1135-4T-0.75	1410	2.94	1.70	0.55	1870	66	34	37
PF/ATEX-1135-4T-1	1410	3.81	2.20	0.75	2100	74	37	39
PF/ATEX-1135-4T-1.5	1410	5.20	3.00	1.1	2400	85	39	43
PF/ATEX-1135-4T-2	1400	6.93	4.00	1.5	2650	95	30	33

¹ The indicated values are determined to 50 Hz motors.

1135

Dimensions mm

Horizontal

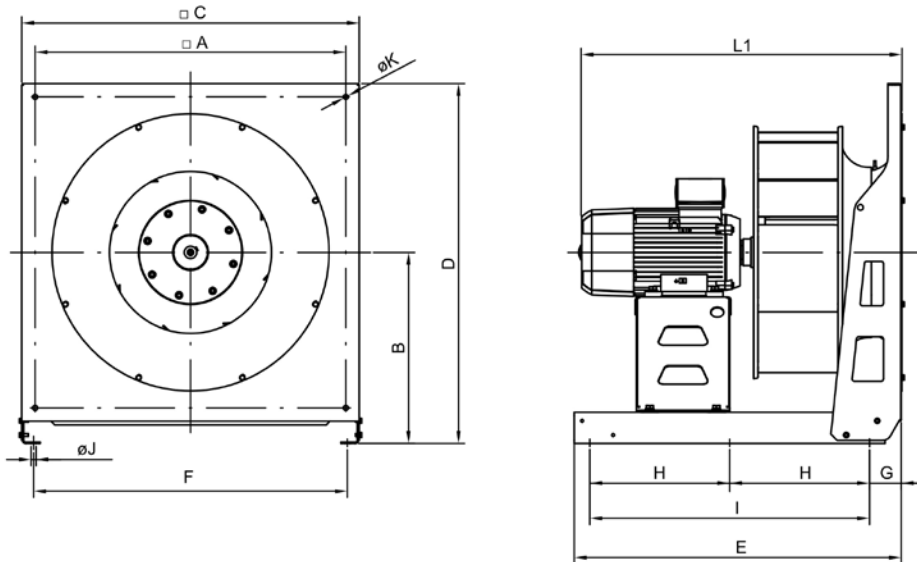

	□A	B	□C	D	E	F	G	H	I	ØJ	ØK	L1
PF-1135-2T-3	475	270	500	520	505	445	70	-	400	9	9	495
PF-1135-4T-0.75	475	270	500	520	505	445	70	-	400	9	9	487
PF-1135-4T-1	475	270	500	520	505	445	70	-	400	9	9	487
PF-1135-4T-1.5	475	270	500	520	505	445	70	-	400	9	9	495
PF-1135-4T-2	475	270	500	520	505	445	70	-	400	9	9	495

Vertical

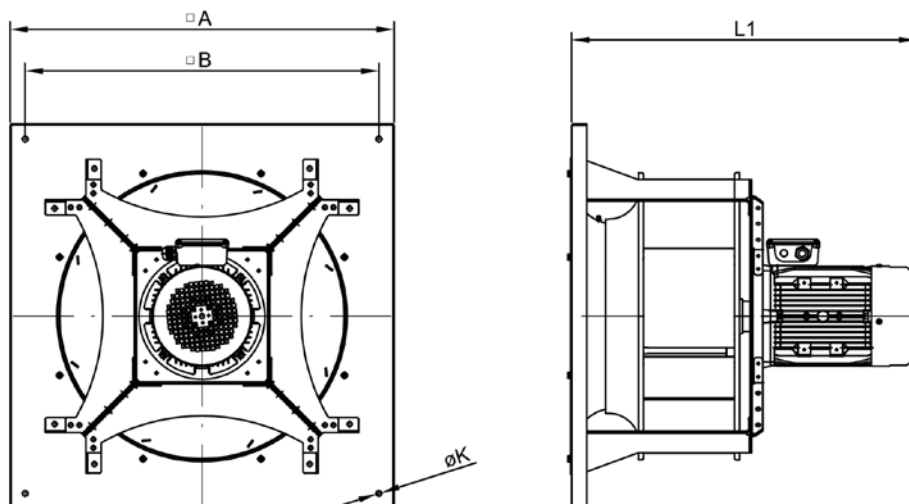

	□A	□B	ØK	L1
PF-1135-2T-3	470	500	11	495
PF-1135-4T-0.75	470	500	11	487
PF-1135-4T-1	470	500	11	487
PF-1135-4T-1.5	470	500	11	495
PF-1135-4T-2	470	500	11	495

1240

Characteristic curves

Q= Flow rate in m³/h, m³/s and cfm

Pe= Static pressure in mm H₂O, Pa and inwg

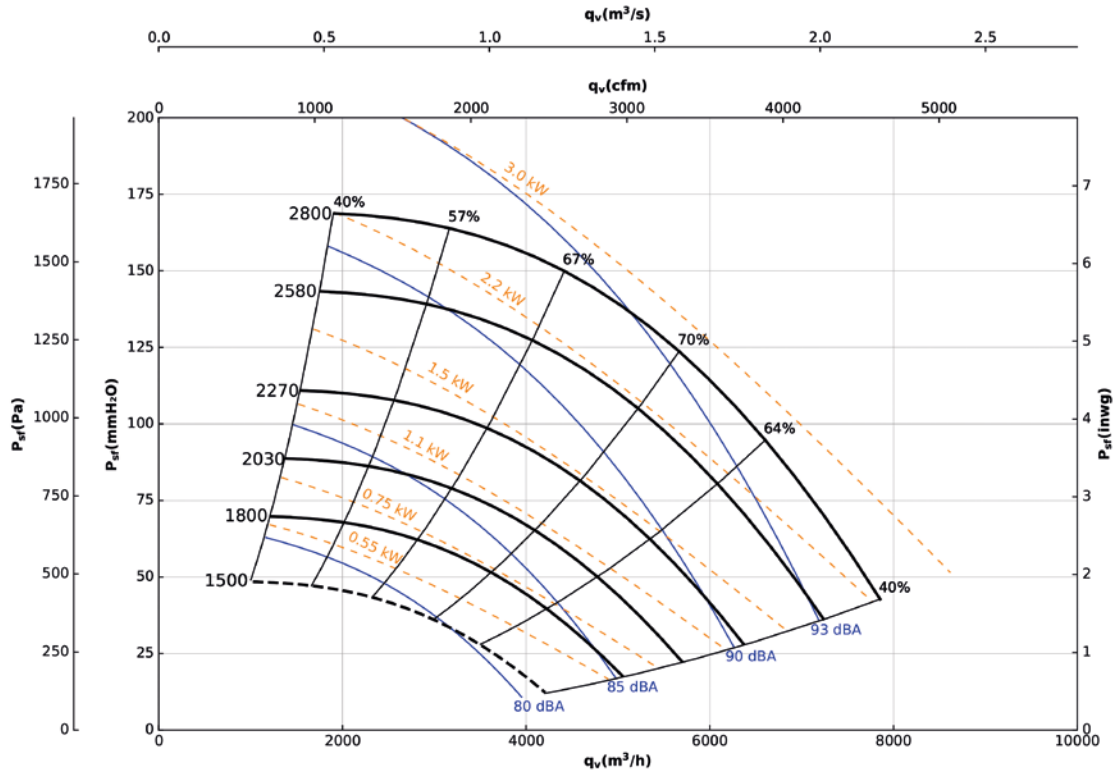

Technical characteristics

Model	Nominal speed ¹ (r/min)	Maximum admissible current (A)		Installed power (kW)	Max. speed (r/min)	Maximum frequency (Hz)	Approx. weight (Kg)	
		230V	400V				Ex eb	Ex db
PF/ATEX-1240-4T-1	1410	3.81	2.20	0.75	1800	64	39	41
PF/ATEX-1240-4T-1.5	1410	5.20	3.00	1.1	2030	72	40	44
PF/ATEX-1240-4T-2	1400	6.93	4.00	1.5	2270	81	31	34
PF/ATEX-1240-4T-3	1410	9.01	2.50	2.2	2580	91	48	50
PF/ATEX-1240-4T-4	1440	12.30	7.10	3	2800	97	45	46

¹ The indicated values are determined to 50 Hz motors.

1240

Dimensions mm

Horizontal

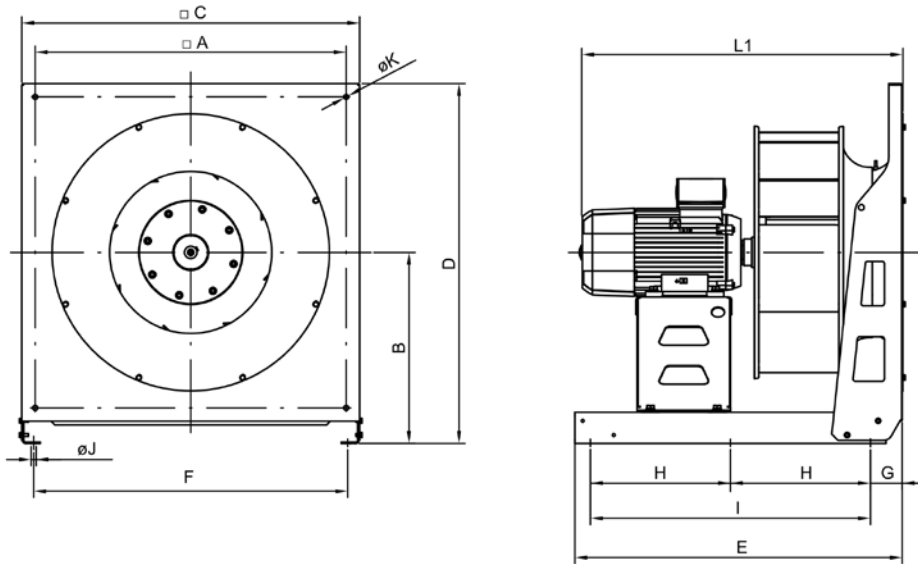

	□A	B	□C	D	E	F	G	H	I	ØJ	ØK	L1
PF-1240-4T-1	475	270	500	520	505	445	70	-	400	9	9	510
PF-1240-4T-1.5	475	270	500	520	505	445	70	-	400	9	9	517
PF-1240-4T-2	475	270	500	520	505	445	70	-	400	9	9	517
PF-1240-4T-3	475	270	500	520	505	445	70	-	400	9	9	582
PF-1240-4T-4	475	270	500	520	505	445	70	-	400	9	9	582

Vertical

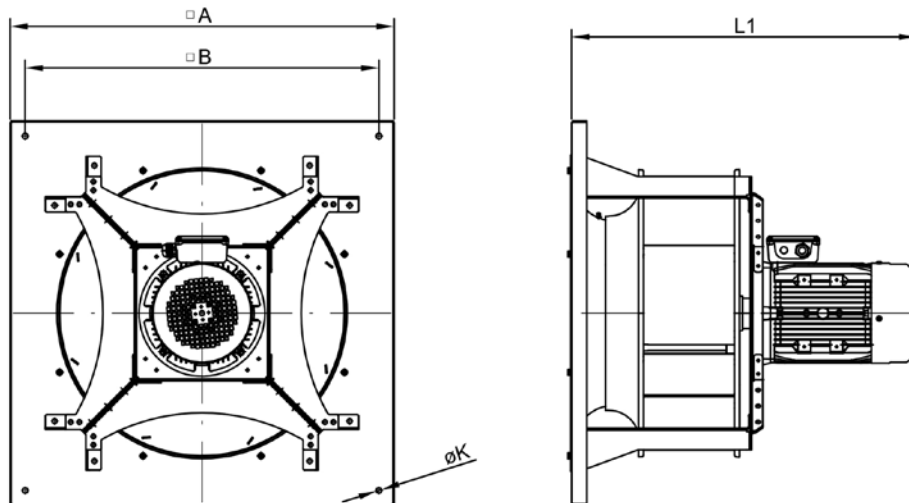

	□A	□B	ØK	L1
PF-1240-4T-1	519	550	11	510
PF-1240-4T-1.5	519	550	11	517
PF-1240-4T-2	519	550	11	517
PF-1240-4T-3	519	550	11	582
PF-1240-4T-4	519	550	11	582

1445

Characteristic curves

Q= Flow rate in m³/h, m³/s and cfm

Pe= Static pressure in mm H₂O, Pa and inwg

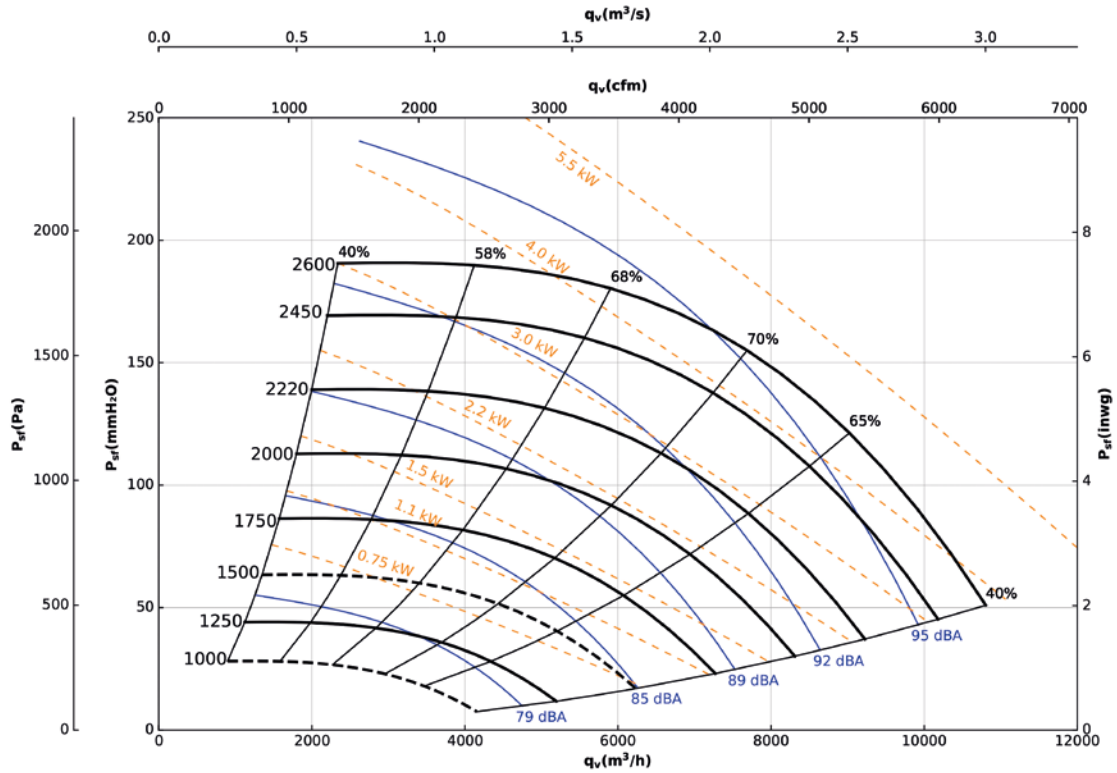

Technical characteristics

Model	Nominal speed ¹ (r/min)	Maximum admissible current (A)			Installed power (kW)	Max. speed (r/min)	Maximum frequency (Hz)	Approx. weight (Kg)	
		230V	400V	690V				Ex eb	Ex db
PF/ATEX-1445-4T-2	1400	6.93	4.00	-	1.5	1750	63	46	49
PF/ATEX-1445-4T-3	1410	9.01	2.50	-	2.2	2000	71	63	65
PF/ATEX-1445-4T-4	1440	12.30	7.10	-	3	2220	77	60	61
PF/ATEX-1445-4T-5.5	1450	15.76	9.10	-	4	2450	84	69	73
PF/ATEX-1445-4T-7.5	1440	-	12.00	6.93	5.5	2600	90	72	97

¹ The indicated values are determined to 50 Hz motors.

1445

Dimensions mm

Horizontal

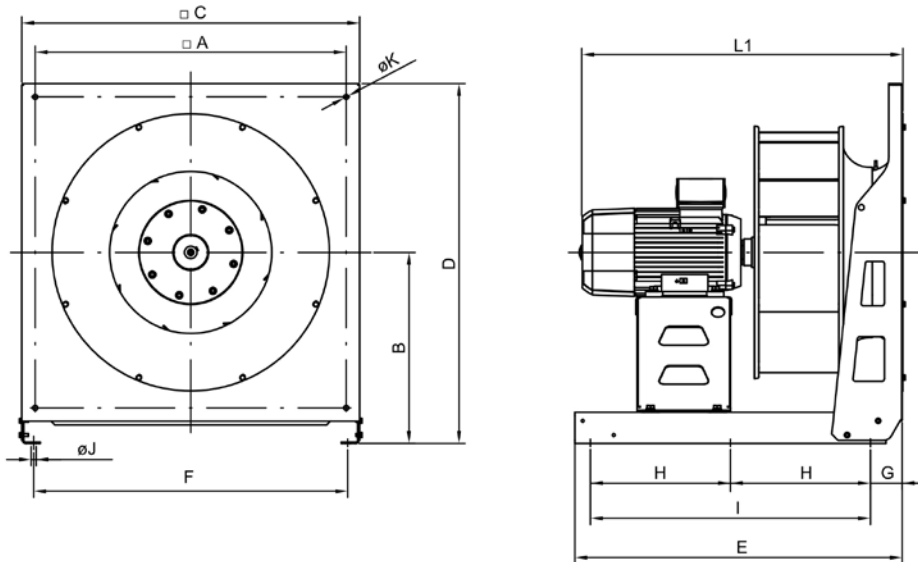

	□A	B	□C	D	E	F	G	H	I	ØJ	ØK	L1
PF-1445-4T-2	580	335	630	650	605	575	70	-	500	9	9	587
PF-1445-4T-3	580	335	630	650	605	575	70	-	500	9	9	610
PF-1445-4T-4	580	335	630	650	605	575	70	-	500	9	9	610
PF-1445-4T-5.5	580	335	630	650	605	575	70	-	500	9	9	625
PF-1445-4T-7.5	580	335	630	650	705	575	70	-	600	9	9	645

Vertical

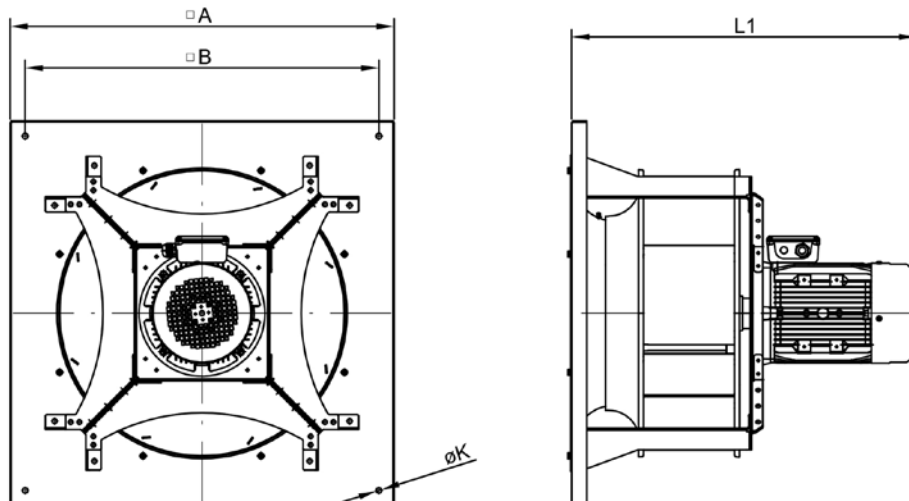

	□A	□B	ØK	L1
PF-1445-4T-2	580	630	11	587
PF-1445-4T-3	580	630	11	610
PF-1445-4T-4	580	630	11	610
PF-1445-4T-5.5	580	630	11	625
PF-1445-4T-7.5	580	630	11	645

1650

Characteristic curves

Q= Flow rate in m³/h, m³/s and cfm Pe= Static pressure in mm H₂O, Pa and inwg

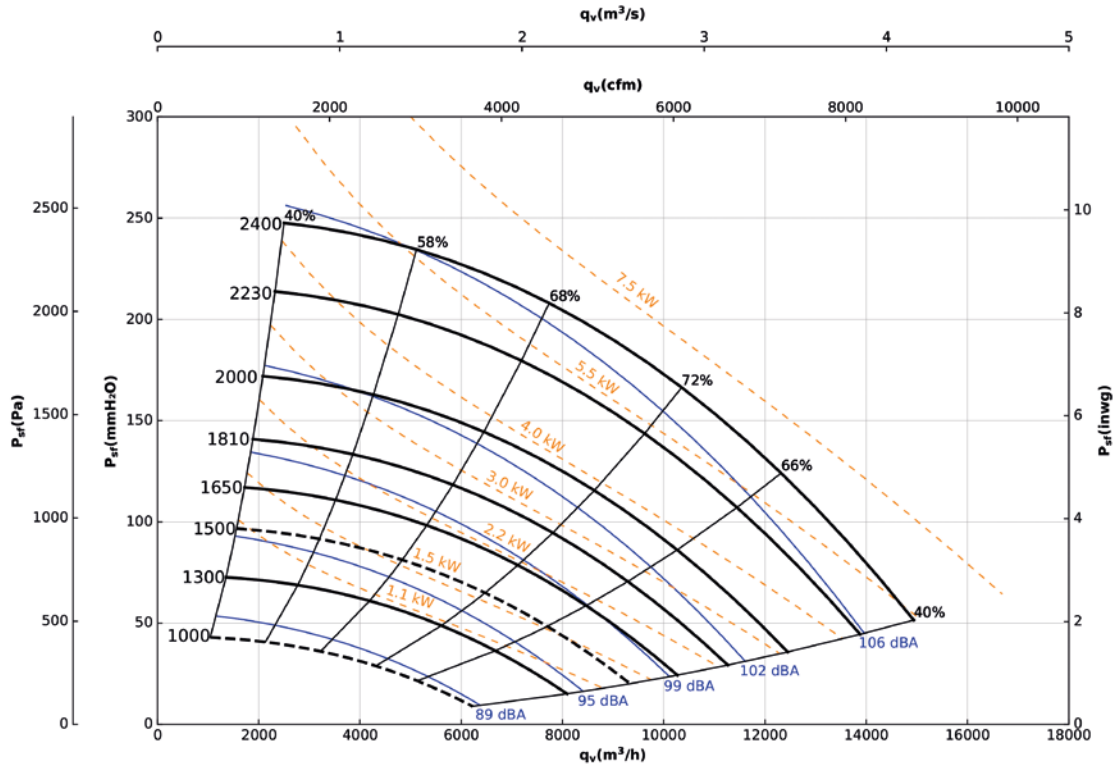

Technical characteristics

Model	Nominal speed ¹ (r/min)	Maximum admissible current (A)			Installed power (kW)	Max. speed (r/min)	Maximum frequency (Hz)	Approx. weight (Kg)	
		230V	400V	690V				Ex eb	Ex db
PF/ATEX-1650-4T-2	1400	6.93	4.00	-	1.5	1440	51	50	53
PF/ATEX-1650-4T-3	1410	9.01	2.50	-	2.2	1650	59	67	69
PF/ATEX-1650-4T-4	1440	12.30	7.10	-	3	1810	63	64	65
PF/ATEX-1650-4T-5.5	1450	15.76	9.10	-	4	2000	69	73	77
PF/ATEX-1650-4T-7.5	1440	-	12.00	6.93	5.5	2230	77	75	100
PF/ATEX-1650-4T-10	1448	-	16.30	9.41	7.5	2400	83	79	98

¹ The indicated values are determined to 50 Hz motors.

1650

Dimensions mm

Horizontal

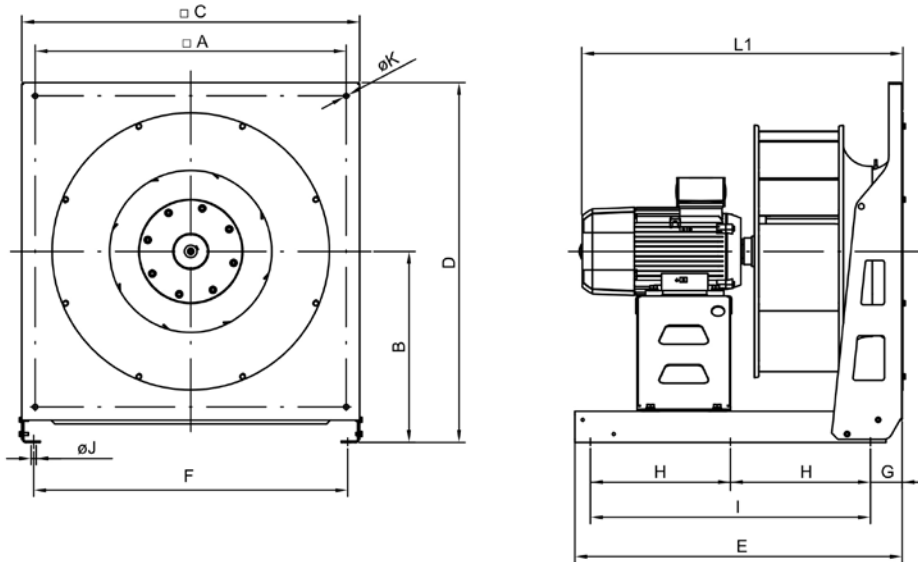

	□A	B	□C	D	E	F	G	H	I	ØJ	ØK	L1
PF-1650-4T-2	600	335	630	650	705	575	70	-	600	9	9	585
PF-1650-4T-3	600	335	630	650	705	575	70	-	600	9	9	647
PF-1650-4T-4	600	335	630	650	705	575	70	-	600	9	9	647
PF-1650-4T-5.5	600	335	630	650	705	575	70	-	600	9	9	662
PF-1650-4T-7.5	600	335	630	650	705	575	70	-	600	9	9	680
PF-1650-4T-10	600	335	630	650	705	575	70	-	600	9	9	680

Vertical

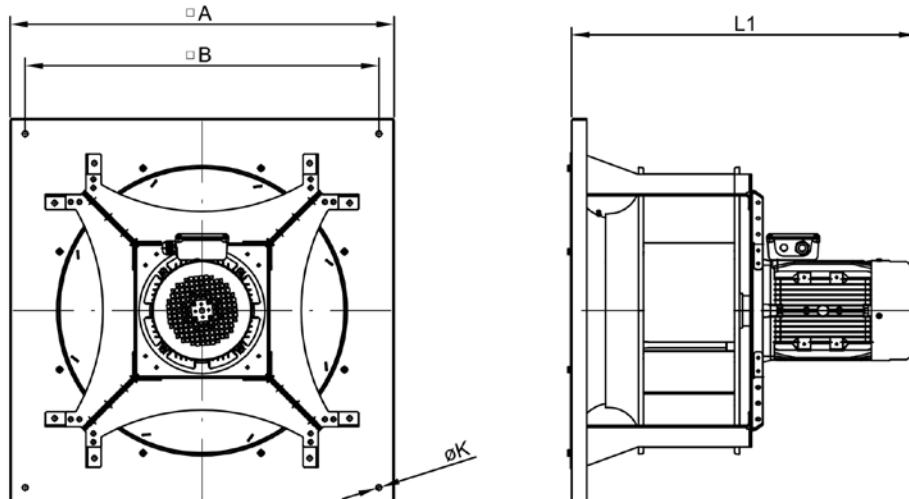

	□A	□B	ØK	L1
PF-1650-4T-2	635	670	11	585
PF-1650-4T-3	635	670	11	647
PF-1650-4T-4	635	670	11	647
PF-1650-4T-5.5	635	670	11	662
PF-1650-4T-7.5	635	670	11	680
PF-1650-4T-10	635	670	11	680

1856

Characteristic curves

Q= Flow rate in m³/h, m³/s and cfm Pe= Static pressure in mm H₂O, Pa and inwg

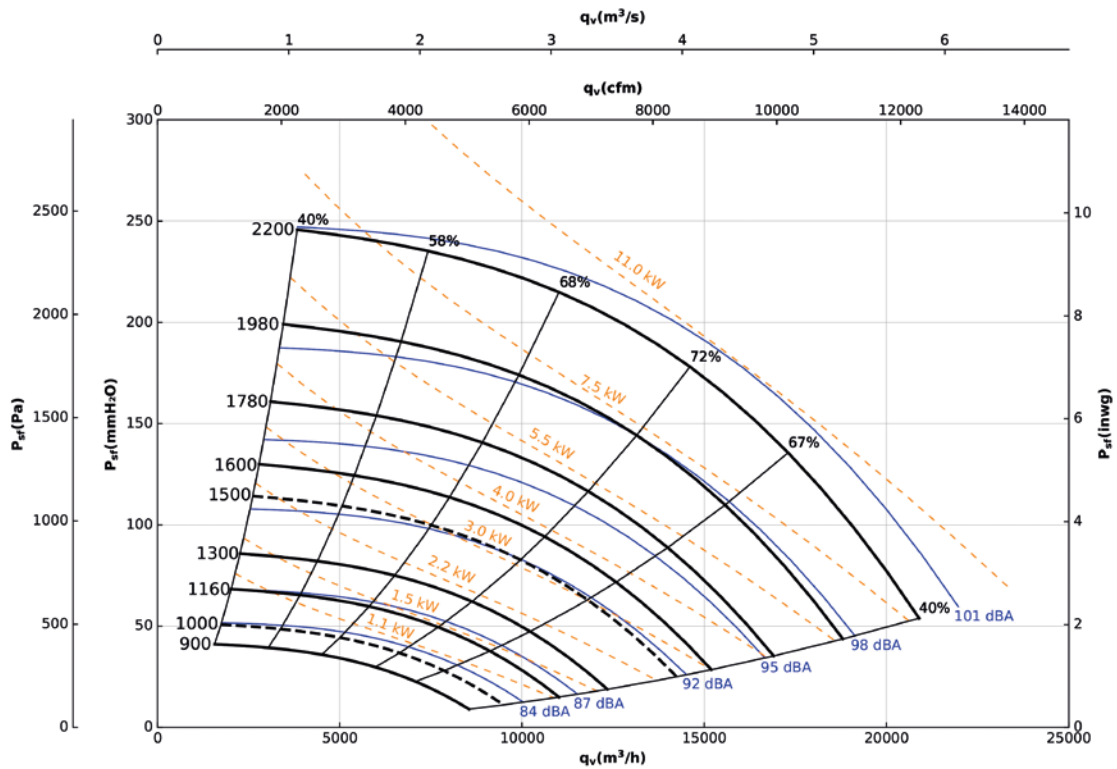

Technical characteristics

Model	Nominal speed ¹ (r/min)	Maximum admissible current (A)			Installed power (kW)	Max. speed (r/min)	Maximum frequency (Hz)	Approx. weight (Kg)	
		230V	400V	690V				Ex eb	Ex db
PF/ATEX-1856-4T-3	1410	9.01	2.50	-	2.2	1300	46	89	91
PF/ATEX-1856-4T-4	1440	12.30	7.10	-	3	1450	50	86	87
PF/ATEX-1856-4T-5.5	1450	15.76	9.10	-	4	1600	55	95	99
PF/ATEX-1856-4T-7.5	1440	-	12.00	6.93	5.5	1780	62	98	123
PF/ATEX-1856-4T-10	1448	-	16.30	9.41	7.5	1980	68	102	121
PF/ATEX-1856-4T-15	1460	-	23.80	13.74	11	2200	75	197	193
PF/ATEX-1856-6T-2	940	7.62	4.40	-	1.5	1160	62	81	87

¹ The indicated values are determined to 50 Hz motors.

1856

Dimensions mm

Horizontal

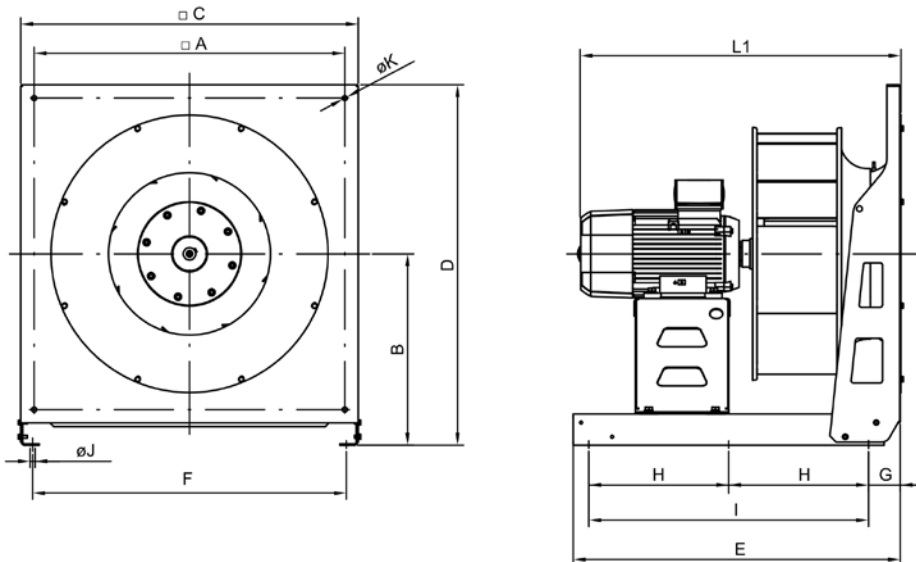

	□A	B	□C	D	E	F	G	H	I	ØJ	ØK	L1
PF-1856-4T-3	700	430	760	810	705	710	70	-	600	9	9	690
PF-1856-4T-4	700	430	760	810	705	710	70	-	600	9	9	690
PF-1856-4T-5.5	700	430	760	810	705	710	70	-	600	9	9	704
PF-1856-4T-7.5	700	430	760	810	805	710	70	-	700	9	9	720
PF-1856-4T-10	700	430	760	810	805	710	70	-	700	9	9	720
PF-1856-4T-15	700	430	760	810	805	710	70	-	700	9	9	892
PF-1856-6T-2	700	430	760	810	705	710	70	-	600	9	9	690

Vertical

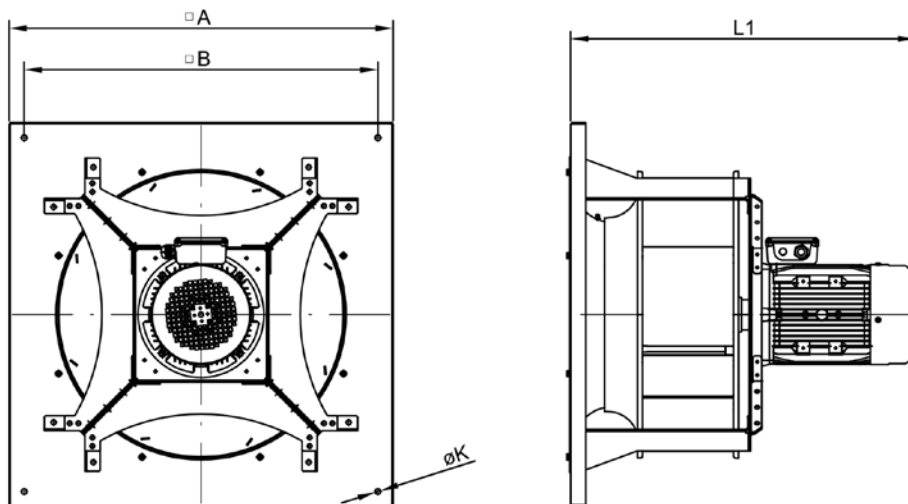

	□A	□B	ØK	L1
PF-1856-4T-3	689	730	11	690
PF-1856-4T-4	689	730	11	690
PF-1856-4T-5.5	689	730	11	704
PF-1856-4T-7.5	689	730	11	720
PF-1856-4T-10	689	730	11	720
PF-1856-4T-15	689	730	11	892
PF-1856-6T-2	689	730	11	690

1663

Characteristic curves

Q= Flow rate in m³/h, m³/s and cfm Pe= Static pressure in mm H₂O, Pa and inwg

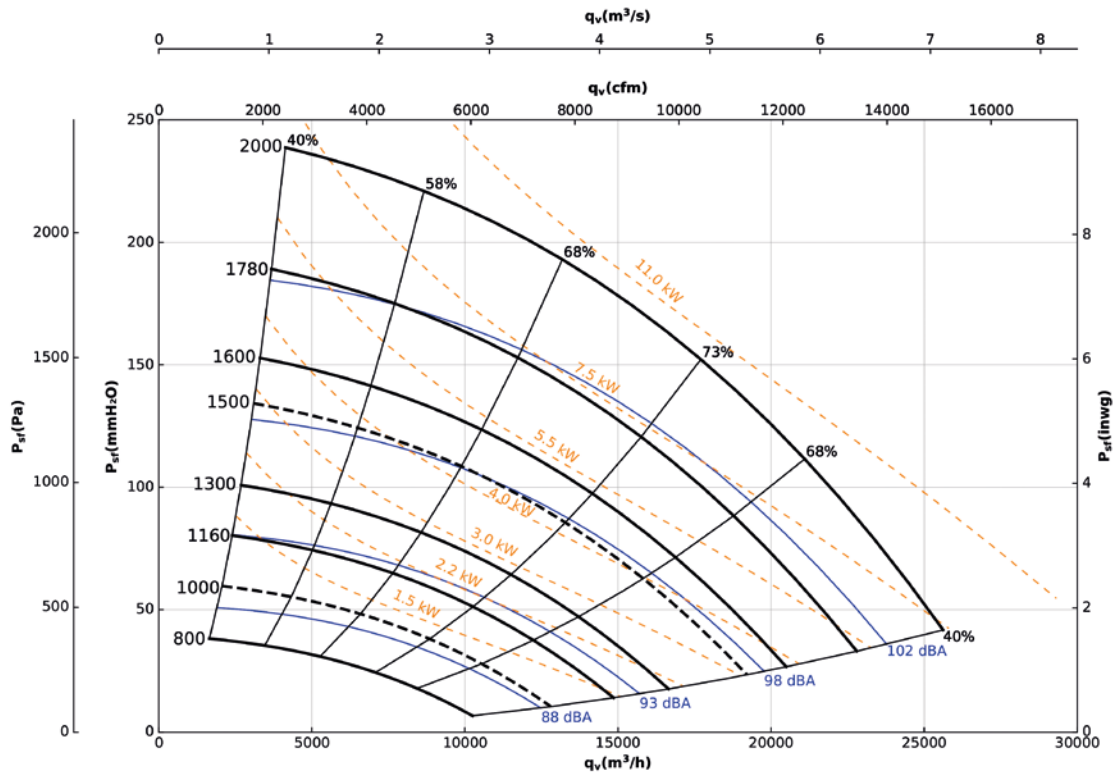

Technical characteristics

Model	Nominal speed ¹ (r/min)	Maximum admissible current (A)			Installed power (kW)	Max. speed (r/min)	Maximum frequency (Hz)	Approx. weight (Kg)	
		230V	400V	690V				Ex eb	Ex db
PF/ATEX-1663-4T-5.5	1450	15.76	9.10	-	4	1440	50	102	106
PF/ATEX-1663-4T-7.5	1440	-	12.00	6.93	5.5	1600	56	104	129
PF/ATEX-1663-4T-10	1448	-	16.30	9.41	7.5	1780	61	108	127
PF/ATEX-1663-4T-15	1460	-	23.80	13.74	11	2000	68	204	200
PF/ATEX-1663-6T-3	940	9.65	5.40	-	2.2	1160	62	93	103
PF/ATEX-1663-6T-4	945	14.72	8.50	-	3	1300	69	103	129

¹ The indicated values are determined to 50 Hz motors.

1663

Dimensions mm

Horizontal

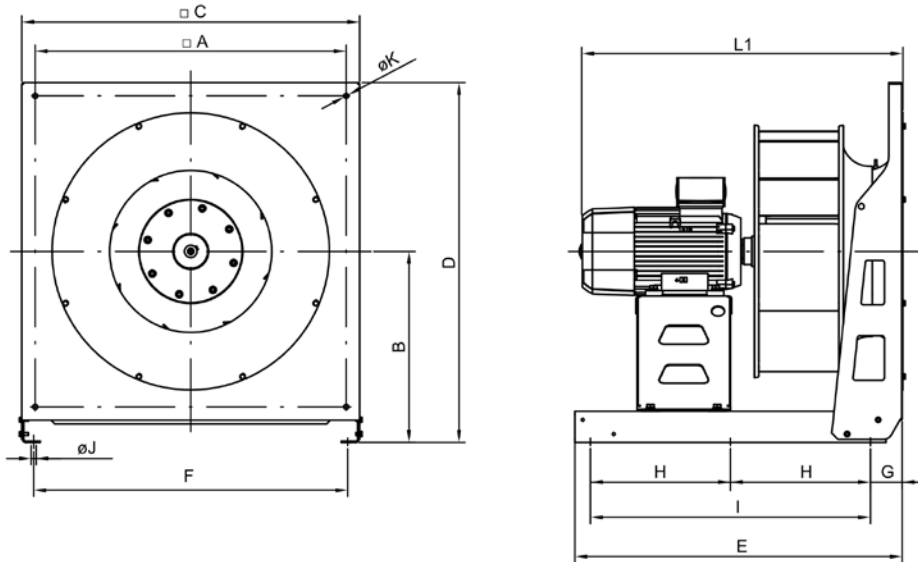

	□A	B	□C	D	E	F	G	H	I	ØJ	ØK	L1
PF-1663-4T-5.5	700	430	760	810	805	705	70	-	700	11	9	776
PF-1663-4T-7.5	700	430	760	810	805	705	70	-	700	11	9	792
PF-1663-4T-10	700	430	760	810	805	705	70	-	700	11	9	792
PF-1663-4T-15	700	430	760	810	905	705	70	400	800	11	9	964
PF-1663-6T-3	700	430	760	810	805	705	70	-	700	11	9	776
PF-1663-6T-4	700	430	760	810	805	705	70	-	700	11	9	792

Vertical

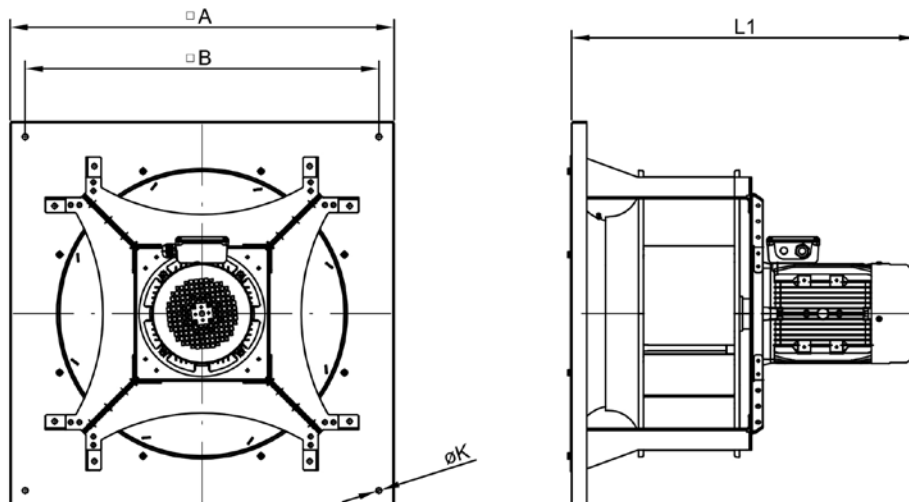

	□A	□B	ØK	L1
PF-1663-4T-5.5	800	840	11	776
PF-1663-4T-7.5	800	840	11	792
PF-1663-4T-10	800	840	11	792
PF-1663-4T-15	800	840	11	964
PF-1663-6T-3	800	840	11	776
PF-1663-6T-4	800	840	11	792

1871

Characteristic curves

Q= Flow rate in m³/h, m³/s and cfm Pe= Static pressure in mm H₂O, Pa and inwg

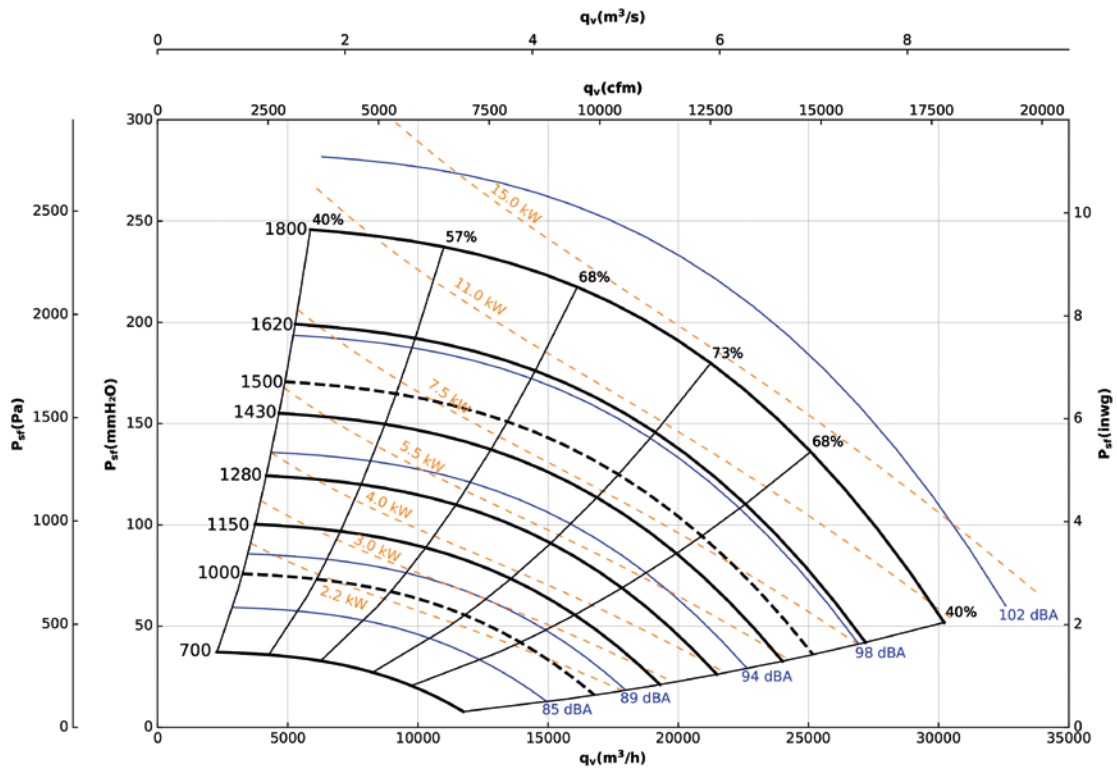

Technical characteristics

Model	Nominal speed ¹ (r/min)	Maximum admissible current (A)			Installed power (kW)	Max. speed (r/min)	Maximum frequency (Hz)	Approx. weight (Kg)	
		230V	400V	690V				Ex eb	Ex db
PF/ATEX-1871-4T-7.5	1440	-	12.00	6.93	5.5	1280	44	176	201
PF/ATEX-1871-4T-10	1448	-	16.30	9.41	7.5	1430	49	175	194
PF/ATEX-1871-4T-15	1460	-	23.80	13.74	11	1620	55	273	269
PF/ATEX-1871-4T-20	1450	-	30.60	17.67	15	1800	62	291	276
PF/ATEX-1871-6T-4	945	14.72	8.50	-	3	1050	56	170	196
PF/ATEX-1871-6T-5.5	950	18.88	10.90	-	4	1150	61	185	205

¹ The indicated values are determined to 50 Hz motors.

1871

Dimensions mm

Horizontal

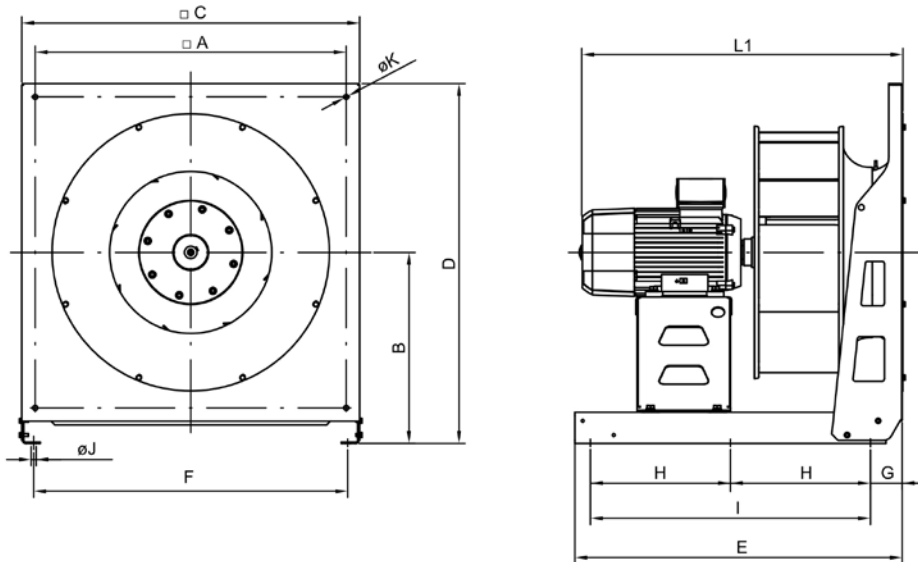

	□A	B	□C	D	E	F	G	H	I	ØJ	ØK	L1
PF-1871-4T-7.5	800	545	960	1025	905	905	70	400	800	11	9	882
PF-1871-4T-10	800	545	960	1025	905	905	70	400	800	11	9	882
PF-1871-4T-15	800	545	960	1025	905	905	70	400	800	11	9	1027
PF-1871-4T-20	800	545	960	1025	905	905	70	400	800	11	9	1027
PF-1871-6T-4	800	545	960	1025	905	905	70	400	800	11	9	882
PF-1871-6T-5.5	800	545	960	1025	905	905	70	400	800	11	9	882

2180

Characteristic curves

Q= Flow rate in m³/h, m³/s and cfm Pe= Static pressure in mm H₂O, Pa and inwg

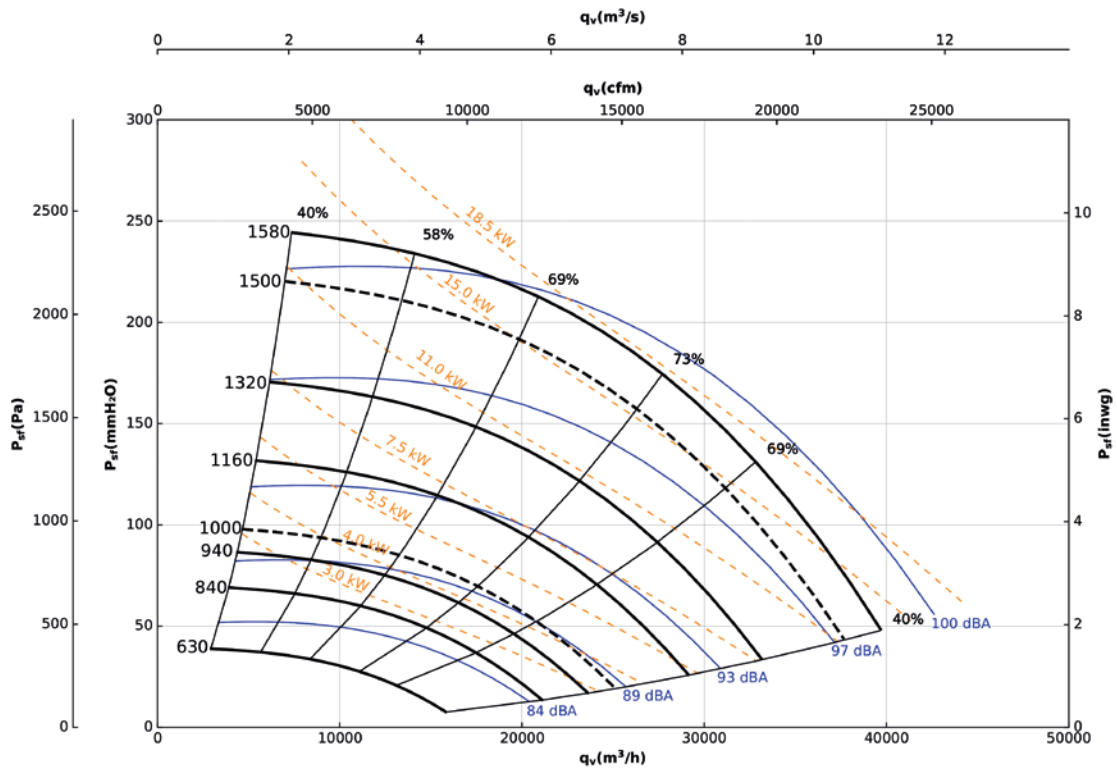

Technical characteristics

Model	Nominal speed ¹ (r/min)	Maximum admissible current (A)			Installed power (kW)	Max. speed (r/min)	Maximum frequency (Hz)	Approx. weight (Kg)	
		230V	400V	690V				Ex eb	Ex db
PF/ATEX-2180-4T-20	1450	-	30.60	17.67	15	1470	51	307	292
PF/ATEX-2180-4T-25	1474	-	35.70	20.60	18.5	1580	54	439	433
PF/ATEX-2180-6T-5.5	950	18.88	10.90	-	4	940	49	201	221
PF/ATEX-2180-6T-7.5	950	-	14.00	8.08	5.5	1040	55	208	223
PF/ATEX-2180-6T-10	965	-	16.40	9.47	7.5	1160	60	239	285
PF/ATEX-2180-6T-15	955	-	23.30	13.45	11	1320	69	276	273

¹ The indicated values are determined to 50 Hz motors.

2180

Dimensions mm

Horizontal

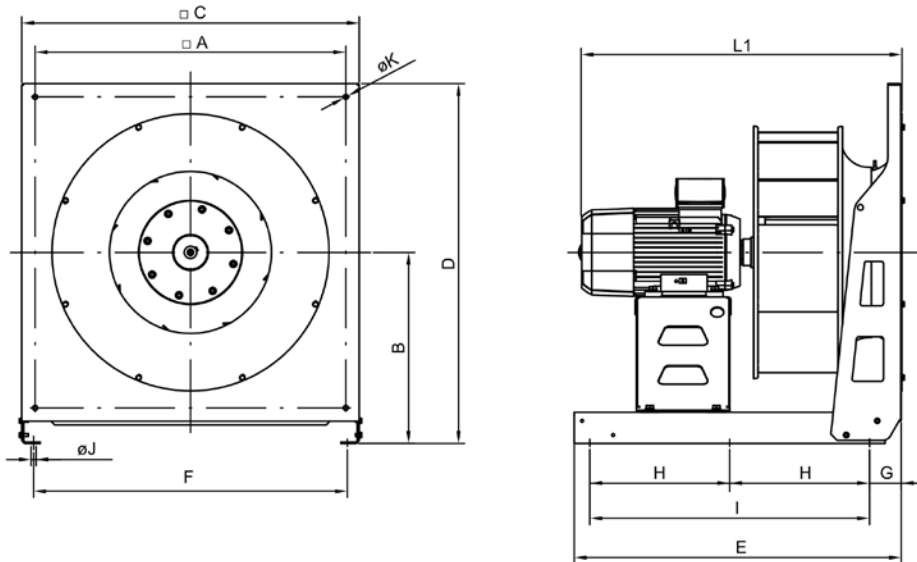

	□A	B	□C	D	E	F	G	H	I	ØJ	ØK	L1
PF-2180-4T-20	900	545	960	1025	1005	895	70	450	900	11	9	1029
PF-2180-4T-25	900	545	960	1025	1005	895	70	450	900	11	9	1111
PF-2180-6T-5.5	900	545	960	1025	1005	895	70	450	900	11	9	929
PF-2180-6T-7.5	900	545	960	1025	1005	895	70	450	900	11	9	929
PF-2180-6T-10	900	545	960	1025	1005	895	70	450	900	11	9	984
PF-2180-6T-15	900	545	960	1025	1005	895	70	450	900	11	9	1029

Pressure connection

Air flow rate → Q [m³/h]
 Calibration factor → K
 Difference in pressure → Δp [Pa]

$$Q = K x \sqrt{\Delta p}$$

	K Factor*
PF-925	77
PF-1028	94
PF-1031	107
PF-1135	143
PF-1240	182
PF-1445	245
PF-1650	225
PF-1856	310
PF-1663	397
PF-1871	513
PF-2180	726

* Values given for ρ = 1.2 kg/m³ and at 20 °C.

